

***** PLEASE READ THE ENTIRE PLAN THOROUGHLY BEFORE STARTING THE PROJECT*****

This PDF document and its contents cannot be sold or used without written permission from ZING WOODWORKS LLC
 Plans, wording and graphics Copyright owned by ZING WOODWORKS LLC



DRAWN: MN	DATE 11/3/2024	ZING WOODWORKS LLC	
CHECKED: N/A		BULL HEAD WALL SHELF	
QA N/A			
UNLESS OTHERWISE SPECIFIED: DIMENSIONS ARE IN INCHES TOLERANCES: ± 0.0625 in		SIZE D	DWG NO TITLE PAGE
		SCALE 1 / 1	PAGE A1
			REV 0

COPYRIGHT

This work and any wording or graphics found in these woodworking plans are for personally use only.
This PDF document and its contents cannot be sold or used without written permission from Zing Woodwork LLC

Plans, wording and graphics Copyright owned by Zing Woodworks LLC

SAFETY WARNING

Woodworking machinery can cause injury from improper operation or from poor maintenance.
Individual machines must be evaluated for specific operating hazards.

Make sure you use hand, eye and hearing protection when using power equipment & always practice safety.

Zing Woodworks LLC is not responsible for injuries or harm caused by improper power tool use
or any injuries related to building this project.

TOOLS NEEDED

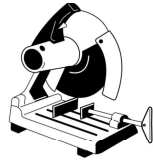

MITER SAW



18 Ga NAILER

MATERIALS NEEDED



STANDARD LUMBER
(1) 1x4 @ 8FT PINE



WOOD GLUE



18 Ga 1-1/4" & 1-1/2" NAILS

VISIT OUR ZING WOODWORKS ETSY STORE FOR MANY MORE WOODWORKING PLANS

https://www.etsy.com/shop/ZingWoodworks?ref=simple-shop-header-name&listing_id=1365901170



WOODWORKING
MADE EASY

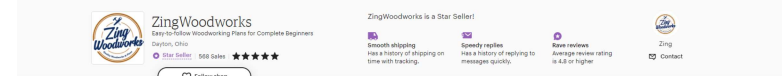

Announcement In 2020, I had to stay home because of the pandemic. And just like many other people, I started doing small home improvement

PLEASE FOLLOW MY YOUTUBE CHANEL FOR MORE PROJECT VIDEOS



Zing Woodworks
@zingwoodworks2137
292 subscribers

HOME VIDEOS SHORTS PLAYLISTS COMMUNITY CHANNELS ABOUT



DRAWN: MN	DATE 11/3/2024	ZING WOODWORKS LLC	
CHECKED: N/A		BULL HEAD WALL SHELF	
QA N/A		SIZE D	DWG NO B-NOTES PAGE
UNLESS OTHERWISE SPECIFIED: DIMENSIONS ARE IN INCHES TOLERANCES: ± 0.0625 in		SCALE	PAGE B1
			REV 0

PARTS LIST			
ITEM	QTY	PART NUMBER	MATERIAL
1	1	1x4 - HORIZONTAL FRAME 1	PINE
2	2	1x4 - ANGLE FRAME	PINE
3	2	1x4 - ANGLE FRAME 2	PINE
4	1	1x4 - HORIZONTAL FRAME 2	PINE
5	1	1x4 - ANGLE FRAME 3	PINE
6	1	1x4 - ANGLE FRAME 4	PINE
7	1	1x4 - ANGLE FRAME 5	PINE
8	2	1x4 - HORIZONTAL FRAME 3	PINE
9	2	1x4 - HORIZONTAL FRAME 4	PINE
10	2	1x4 - ANGLE FRAME 6	PINE
11	2	1x4 - ANGLE FRAME 7	PINE
12	2	1x4 - ANGLE FRAME 8	PINE

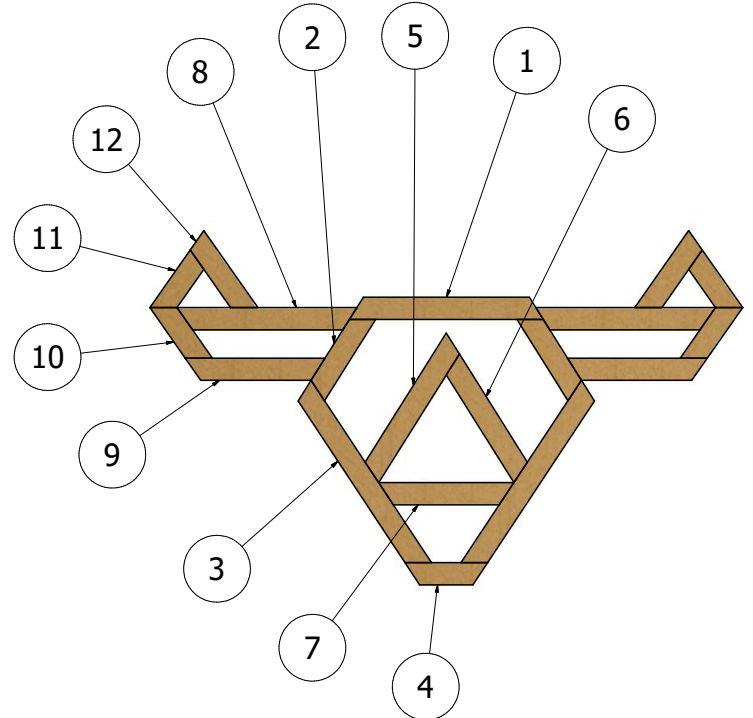
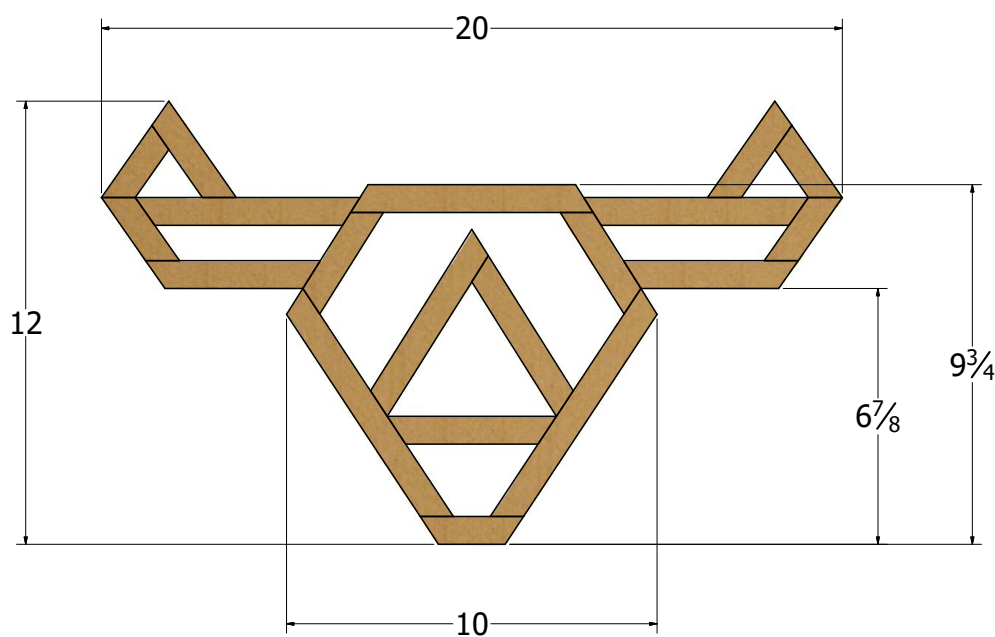
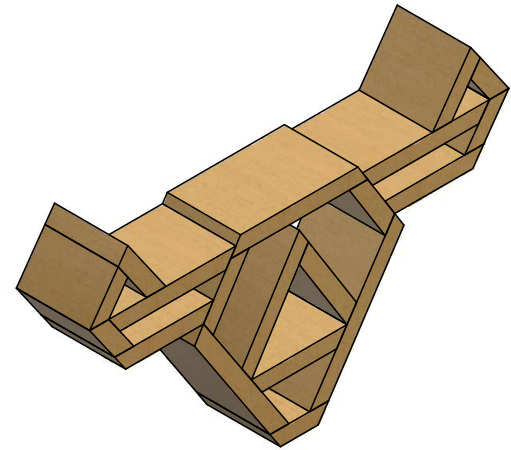

This PDF document and its contents cannot be sold or used without written permission from ZING WOODWORKS LLC
Plans, wording and graphics Copyright owned by ZING WOODWORKS LLC



DRAWN: MN	DATE 11/3/2024	ZING WOODWORKS LLC	
CHECKED: N/A		BULL HEAD WALL SHELF	
QA N/A		SIZE D	DWG NO TOTAL ASSEMBLY
UNLESS OTHERWISE SPECIFIED: DIMENSIONS ARE IN INCHES TOLERANCES: ± 0.0625 in		SCALE 1/2.5	PAGE C1
			REV 0

CUT LIST - 1

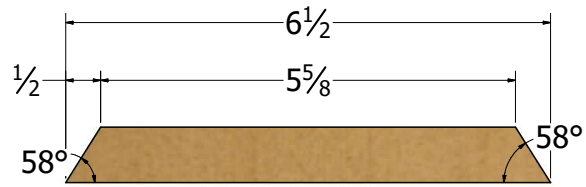

1 1x4 - HORIZONTAL FRAME 1
MATERIAL: PINE
QTY: 1

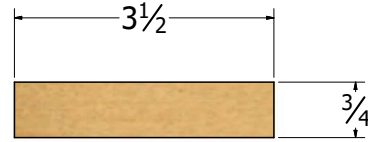

2 1x4 - ANGLE FRAME
MATERIAL: PINE
QTY: 2

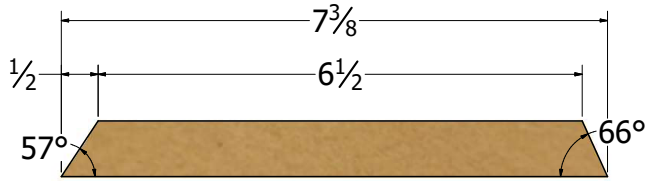
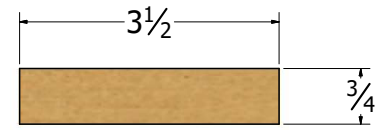
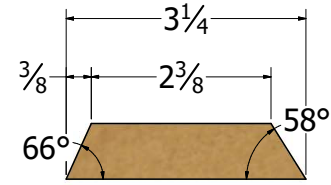

3 1x4 - ANGLE FRAME 2
MATERIAL: PINE
QTY: 2

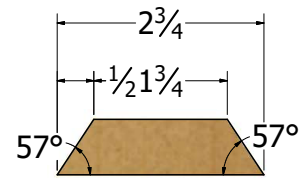
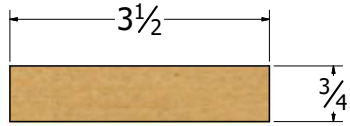

4 1x4 - HORIZONTAL FRAME 2
MATERIAL: PINE
QTY: 1

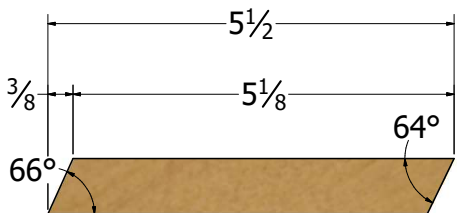
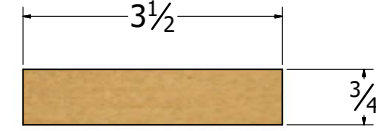

5 1x4 - ANGLE FRAME 3
MATERIAL: PINE
QTY: 1

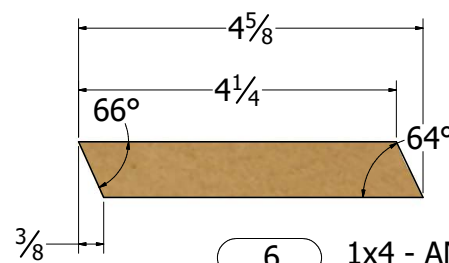
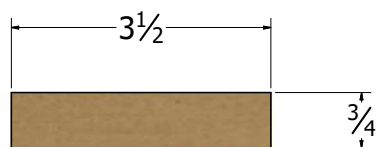

6 1x4 - ANGLE FRAME 4
MATERIAL: PINE
QTY: 1

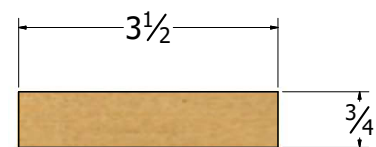

This PDF document and its contents cannot be sold or used without written permission from ZING WOODWORKS LLC
Plans, wording and graphics Copyright owned by ZING WOODWORKS LLC



DRAWN: MN	DATE 11/3/2024
CHECKED: N/A	
QA N/A	
UNLESS OTHERWISE SPECIFIED: DIMENSIONS ARE IN INCHES TOLERANCES: ± 0.0625 in	

ZING WOODWORKS LLC		
BULL HEAD WALL SHELF		
SIZE D	DWG NO	PAGE
SCALE 1:1	TOTAL ASSEMBLY	C2
		REV 0

CUT LIST - 2

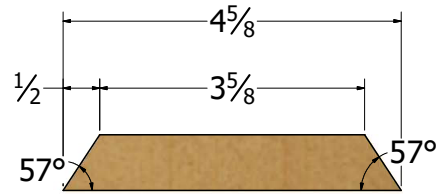

7 1x4 - ANGLE FRAME 5
MATERIAL: PINE
QTY: 1

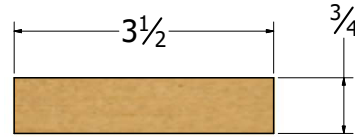

8 1x4 - HORIZONTAL FRAME 3
MATERIAL: PINE
QTY: 2

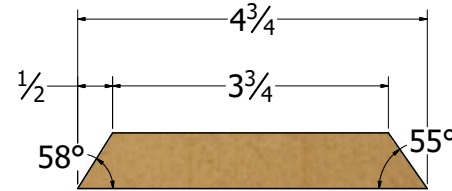
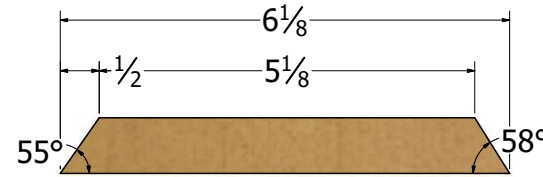

9 1x4 - HORIZONTAL FRAME 4
MATERIAL: PINE
QTY: 2

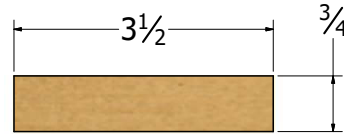

10 1x4 - ANGLE FRAME 6
MATERIAL: PINE
QTY: 2

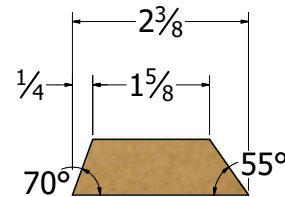
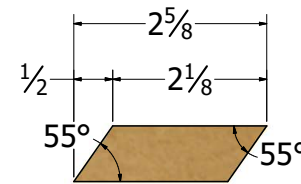

11 1x4 - ANGLE FRAME 7
MATERIAL: PINE
QTY: 2

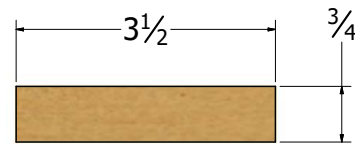

12 1x4 - ANGLE FRAME 8
MATERIAL: PINE
QTY: 2

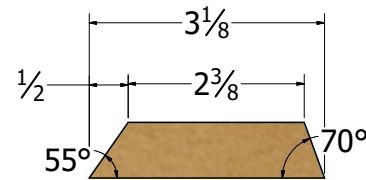

This PDF document and its contents cannot be sold or used without written permission from ZING WOODWORKS LLC
Plans, wording and graphics Copyright owned by ZING WOODWORKS LLC



DRAWN: MN	DATE 11/3/2024	ZING WOODWORKS LLC	
CHECKED: N/A		BULL HEAD WALL SHELF	
QA N/A			
UNLESS OTHERWISE SPECIFIED: DIMENSIONS ARE IN INCHES TOLERANCES: ± 0.0625 in		SIZE D	DWG NO TOTAL ASSEMBLY
		SCALE 1 : 1	PAGE C3
			REV 0

STEP 1: ASSEMBLY MAIN MODULE



USE WOOD GLUE AND
18 GA 1 1/4" NAILS TO ATTACH

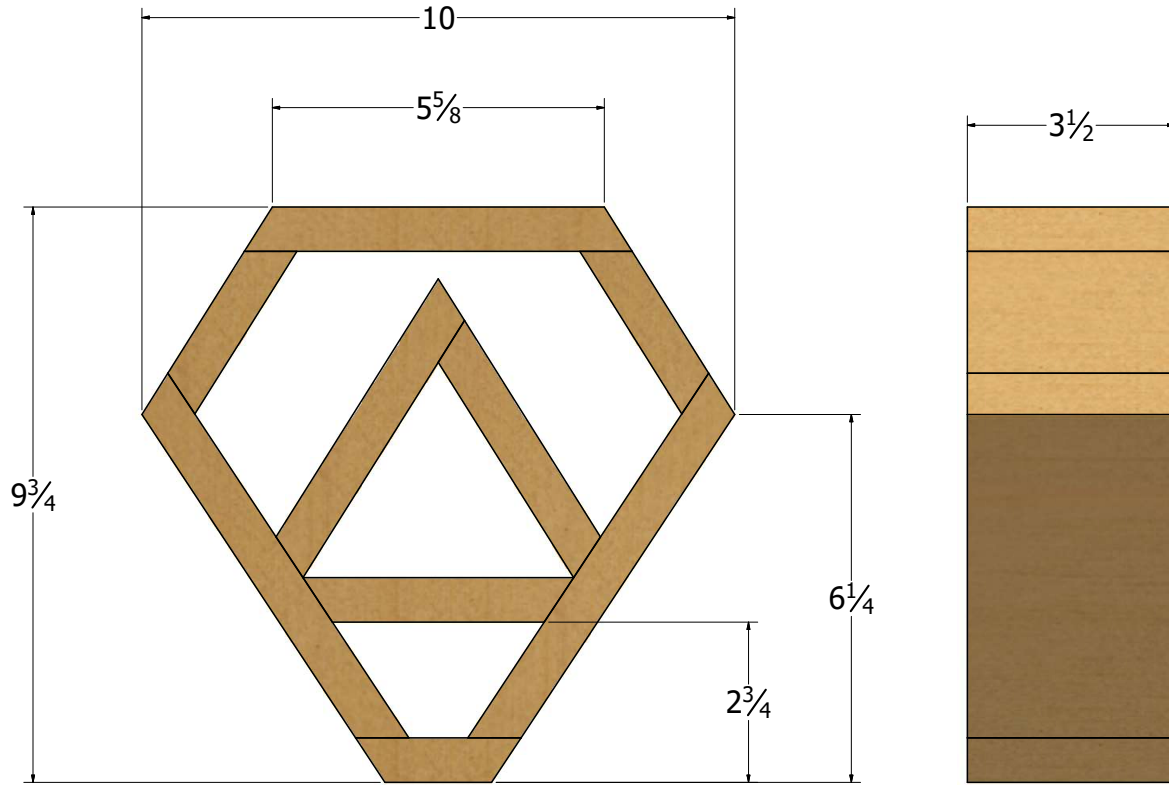
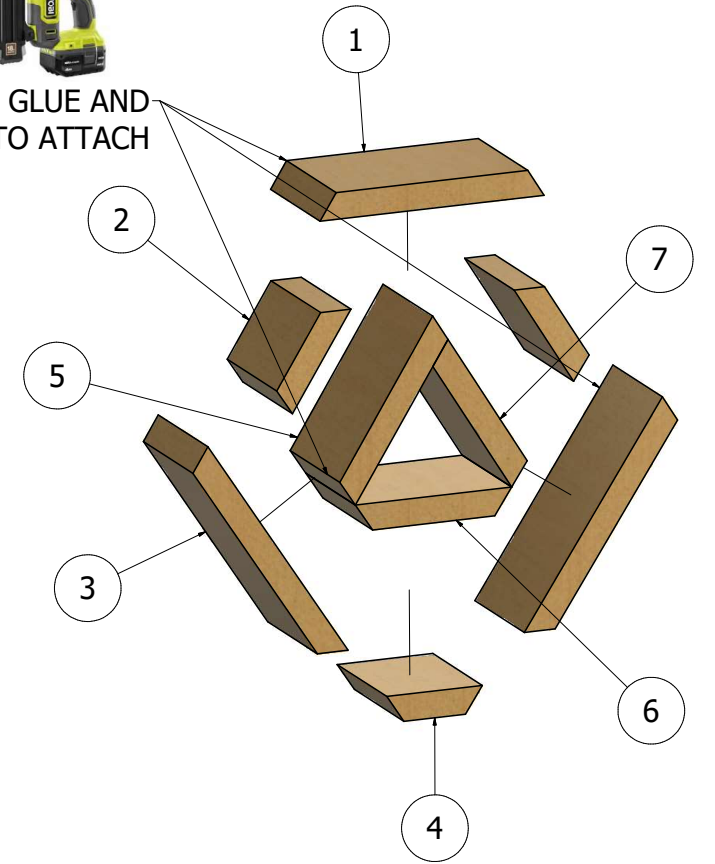

This PDF document and its contents cannot be sold or used without written permission from ZING WOODWORKS LLC
Plans, wording and graphics Copyright owned by ZING WOODWORKS LLC



DRAWN: MN	DATE 11/3/2024	ZING WOODWORKS LLC	
CHECKED: N/A		BULL HEAD WALL SHELF	
QA N/A			
UNLESS OTHERWISE SPECIFIED: DIMENSIONS ARE IN INCHES TOLERANCES: ± 0.0625 in		SIZE D	DWG NO BUILDING STEPS
		SCALE	PAGE D1
			REV 0

STEP 2: ASSEMBLE LEFT - RIGHT MODULE



USE WOOD GLUE AND
18 GA 1 1/4" NAILS TO ATTACH

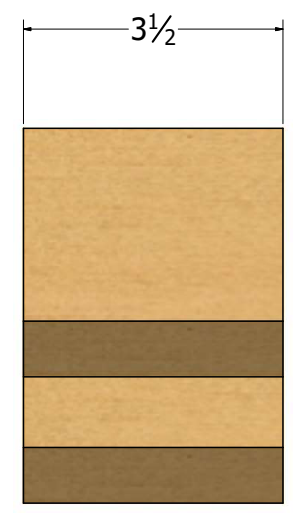
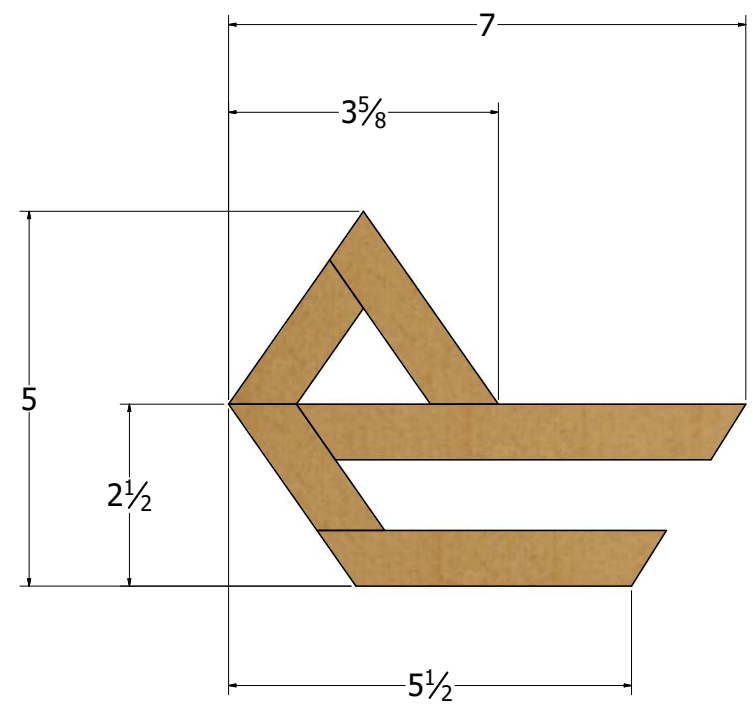
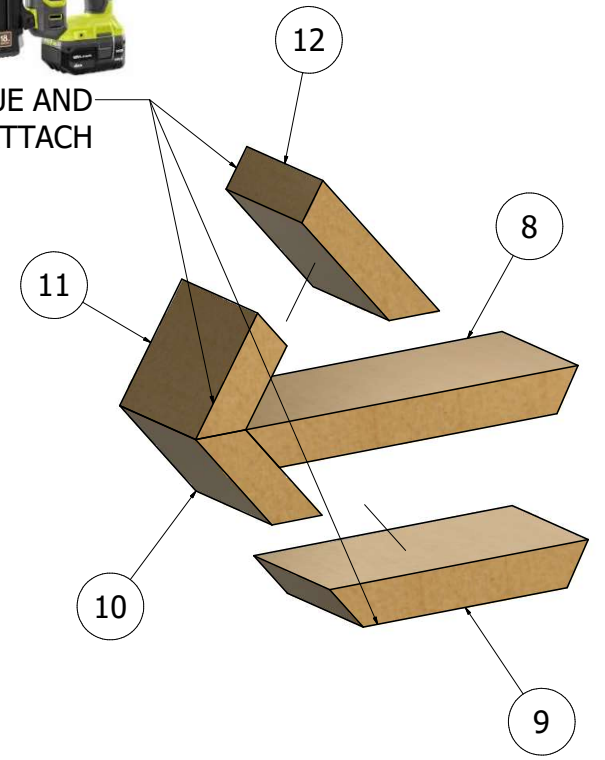

Q.TY NEED: 2 SET

This PDF document and its contents cannot be sold or used without written permission from ZING WOODWORKS LLC
Plans, wording and graphics Copyright owned by ZING WOODWORKS LLC



DRAWN: MN	DATE 11/3/2024	ZING WOODWORKS LLC	
CHECKED: N/A		BULL HEAD WALL SHELF	
QA N/A		SIZE D	DWG NO BUILDING STEPS
UNLESS OTHERWISE SPECIFIED: DIMENSIONS ARE IN INCHES TOLERANCES: ± 0.0625 in		SCALE	PAGE D2
			REV 0

STEP 3: ATTACH LEFT, RIGHT MODULE TO MAIN MODULE

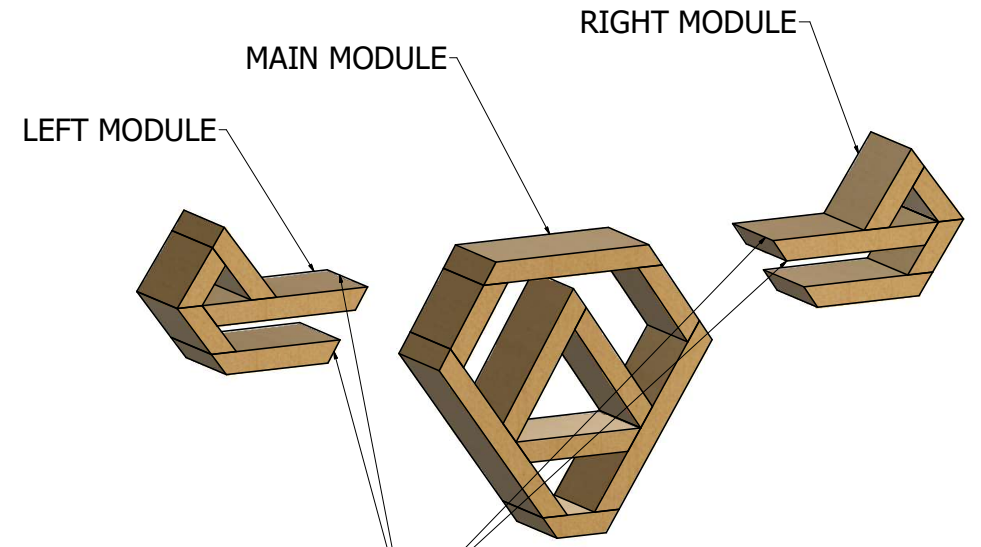
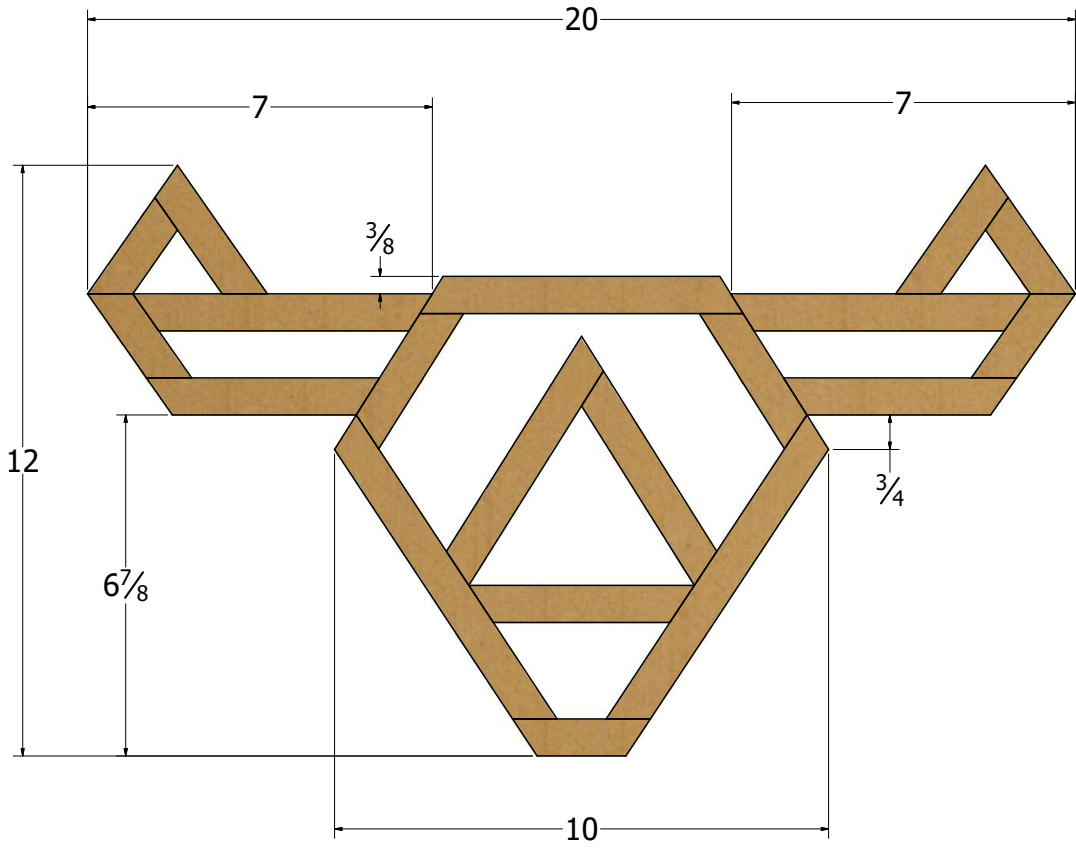

USE WOOD GLUE AND 18 GA 1 1/2" NAILS TO ATTACH



This PDF document and its contents cannot be sold or used without written permission from ZING WOODWORKS LLC
Plans, wording and graphics Copyright owned by ZING WOODWORKS LLC



DRAWN: MN	DATE 11/3/2024	ZING WOODWORKS LLC		
CHECKED: N/A		BULL HEAD WALL SHELF		
QA N/A				
UNLESS OTHERWISE SPECIFIED: DIMENSIONS ARE IN INCHES TOLERANCES: ± 0.0625 in		SIZE D	DWG NO BUILDING STEPS	PAGE D3
		SCALE		REV 0

FINISH BULL HEAD WALL SHELF. STAIN WITH COLOR OF YOUR CHOICE

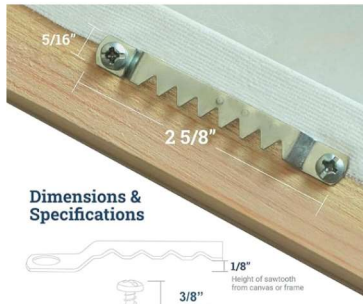

10 Pack - Large Sawtooth Hangers with Screws
 Canvas Hanger - Sawtooth Hanger
 Visit the 888 Corp Store
 4.7 ★★★★★ 851 ratings
 Amazon's Choice
 500+ bought in past month
 Best Price on Amazon
 -20% \$4.95
 Typical price: \$6.20 @
 Prime Two-Day
 FREE Returns
 Best price
 Pay \$4.95 \$0.23 after using available Amazon Visa rewards points.
 Material Metal
 Brand 888 Corp
 Color Zinc
 Installation Type Screw-in
 Fastener Type Sawtooth

Dimensions & Specifications

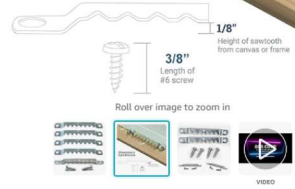

ATTACH SAWTOOTH HANGER HARDWARE TO BACK OF THE SHELF TO HANG ON WALL

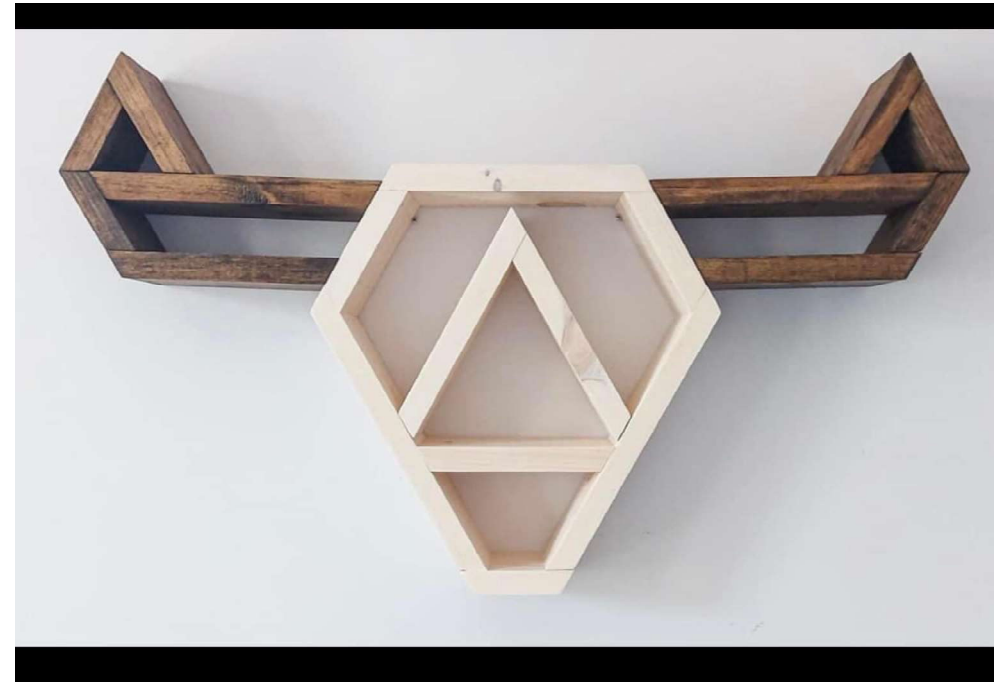

This PDF document and its contents cannot be sold or used without written permission from ZING WOODWORKS LLC
 Plans, wording and graphics Copyright owned by ZING WOODWORKS LLC



DRAWN: MN	DATE 11/3/2024	ZING WOODWORKS LLC	
CHECKED: N/A		BULL HEAD WALL SHELF	
QA N/A			
UNLESS OTHERWISE SPECIFIED: DIMENSIONS ARE IN INCHES TOLERANCES: ± 0.0625 in		SIZE D	DWG NO BUILDING STEPS
		SCALE	PAGE D4 REV 0

