

Planter Bench

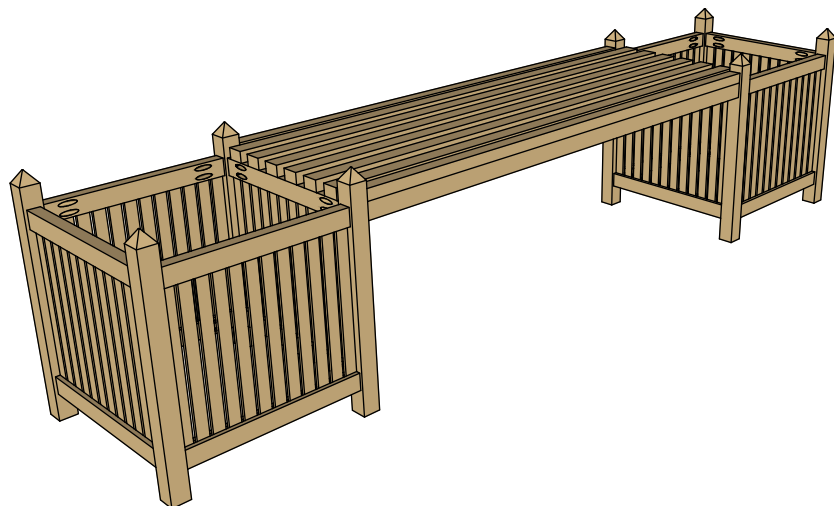

(<https://www.youtube.com/c/MatthewPeechWoodworkingAndDIY>)

Perspectives

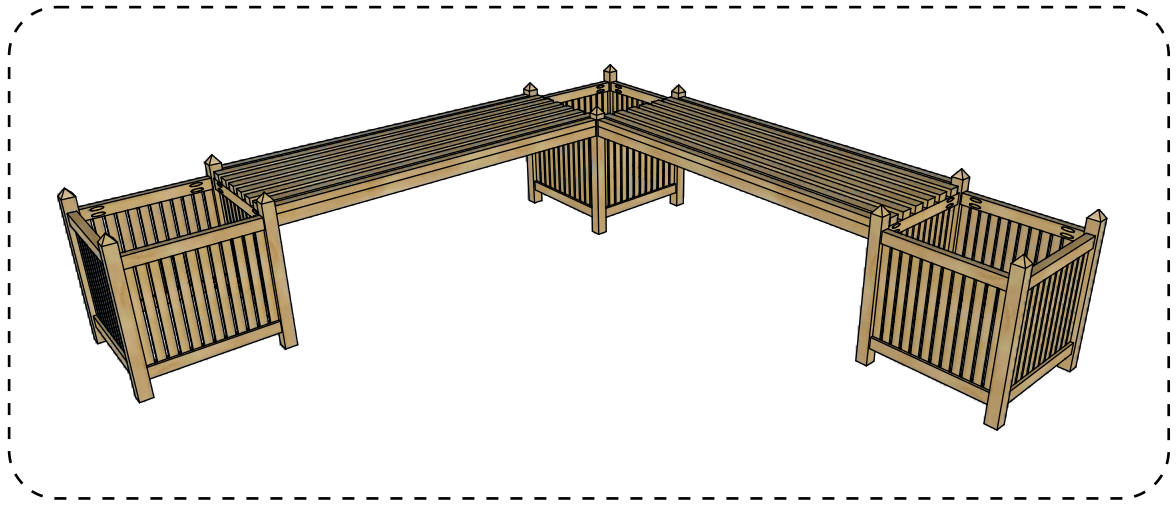
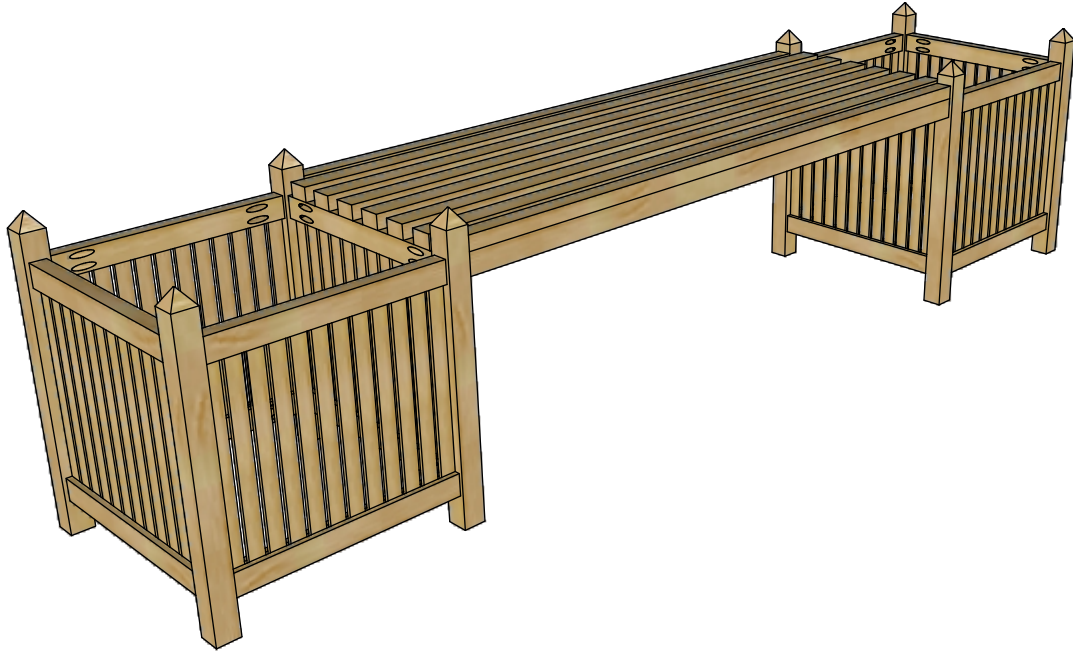

SCAN THIS CODE
TO GO TO THE
YOUTUBE CHANNEL



<https://www.youtube.com/c/MatthewPeechWoodworkingAndDIY>

Overall Dimensions

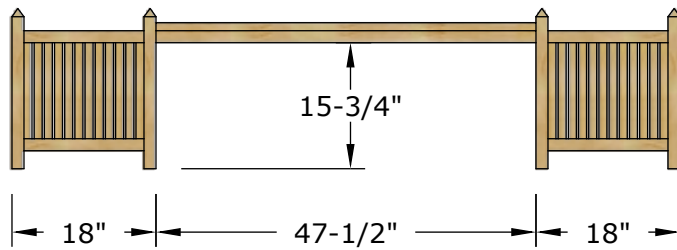

Front

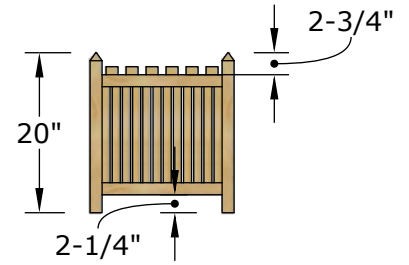

Side

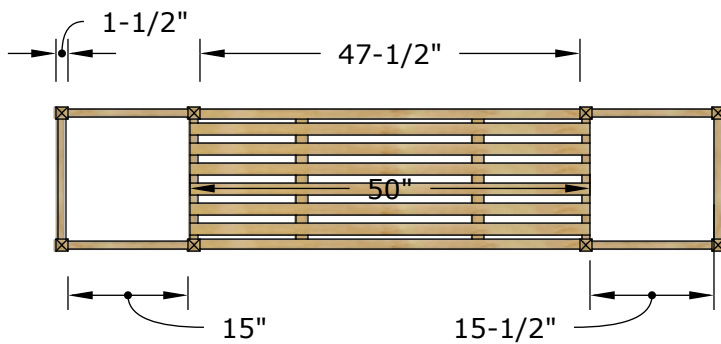

Top



(<https://www.youtube.com/c/MatthewPeechWoodworkingAndDIY>)

Exploded

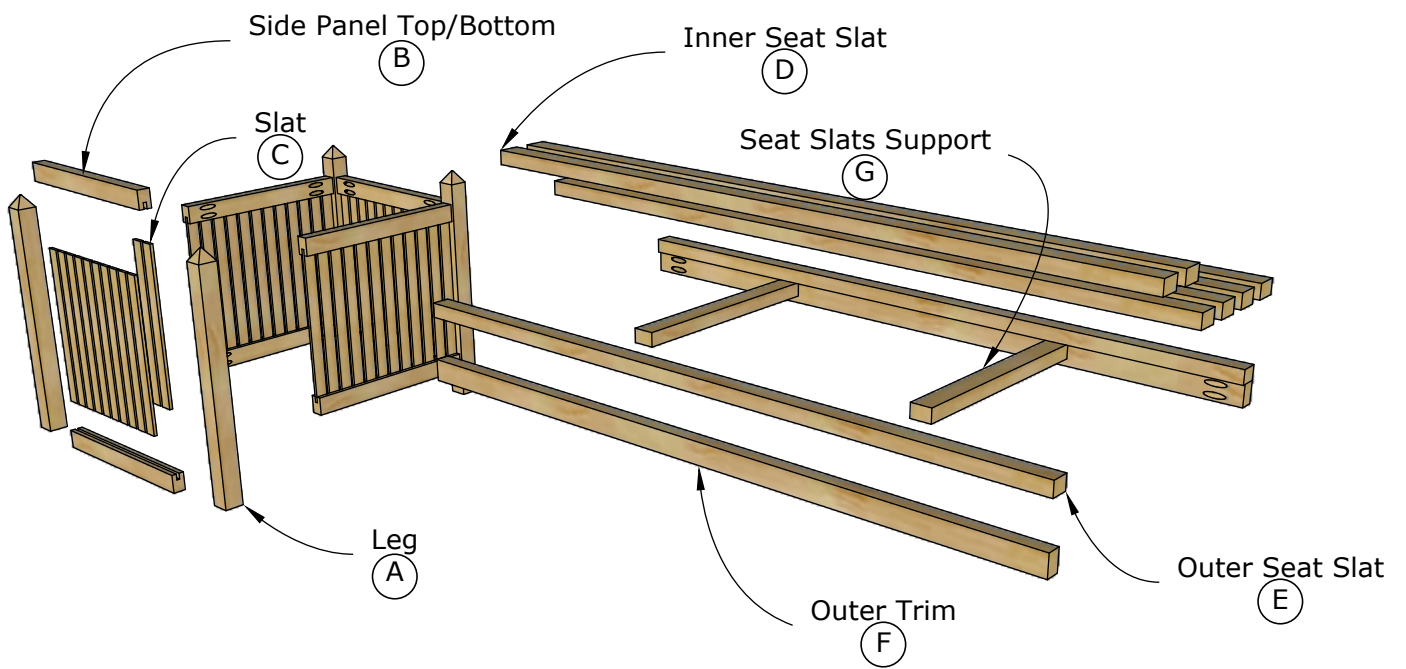

(<https://www.youtube.com/c/MatthewPeechWoodworkingAndDIY>)

1 Cut Material - Option (a):

Parts list will be for one planter and one bench. Duplicate for desired quantities.

Cutting List

Part	Description	Quantity	Length	Width	Thickness	Material
A	Leg	4	20"	1 1/2"	1 1/2"	Wood
B	Side Panel Top/Bottom	8	15"	1"	1 1/2"	Wood
C	Slat	48	13"	1"	1/4"	Wood
D	Inner Seat Slat	6	50"	1"	1 1/2"	Wood
E	Outer Seat Slat	2	47 1/2"	1"	1 1/4"	Wood
F	Outer Trim	2	47 1/2"	1"	1 1/2"	Wood
G	Seat Slats Support	2	15 1/2"	1"	1 1/2"	Wood

Cutting Diagram

1 1/2" x 7-1/4" -96" (One Board*)

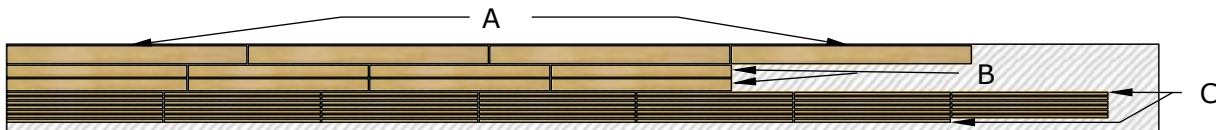

1 1/2" x 7-1/4" -120" (One Board**)

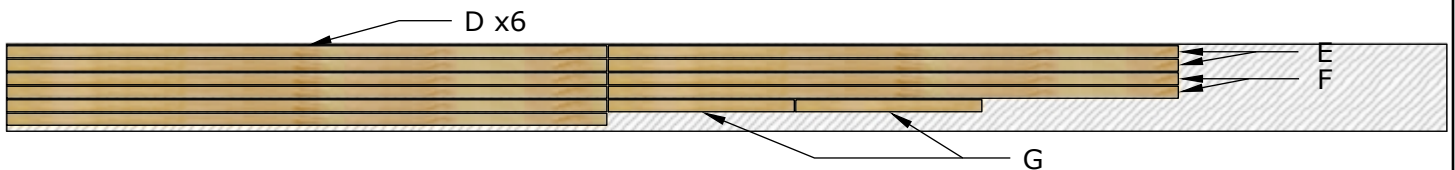

*Planter parts cut from one 2x8x8' (1 1/2"x 7 1/4 x 96") Start by removing the rounded sides of the 2x8. (1/8" from each side).

**To get all parts from one board use a 2" x 8" x 10' (1 1/2"x 7 1/4 x 120")



(<https://www.youtube.com/c/MatthewPeechWoodworkingAndDIY>)

Cut Material - Option (b):

If you are making the three planter and two bench design, the following cut list will optimize your material.

Cutting List

Part	Description	Quantity	Length	Width	Thickness	Material
A	Leg	12	20"	1 1/2"	1 1/2"	Wood
B	Side Panel Top/Bottom	24	15"	1"	1 1/2"	Wood
C	Slat	144	13"	1"	1/4"	Wood
D	Inner Seat Slat	12	50"	1"	1 1/2"	Wood
E	Outer Seat Slat	4	47 1/2"	1"	1 1/4"	Wood
F	Outer Trim	4	47 1/2"	1"	1 1/2"	Wood
G	Seat Slats Support	4	15 1/2"	1"	1 1/2"	Wood

Cutting Diagram

1 1/2" x 5-1/2" -96" (Four Boards)

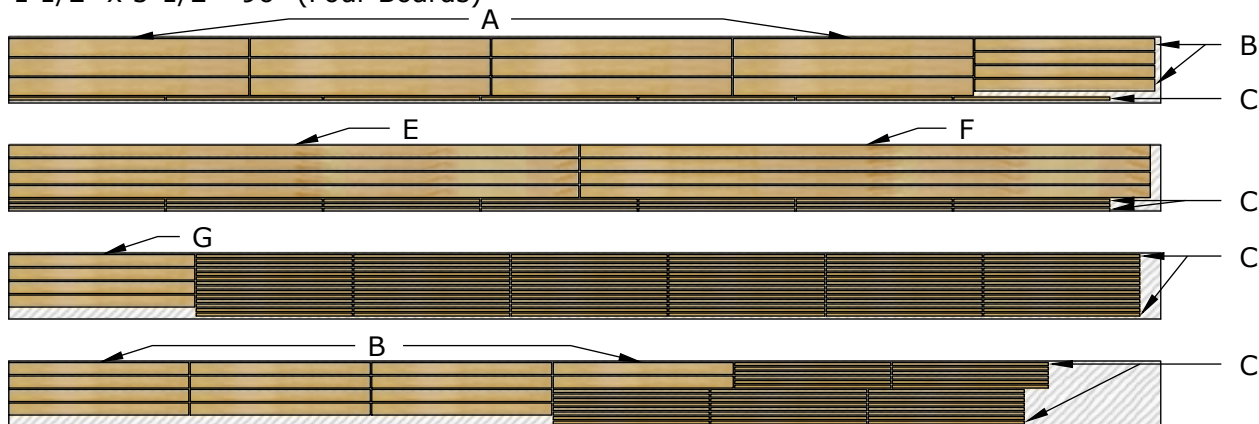

1 1/2" x 7-1/4" -120" (One Board)

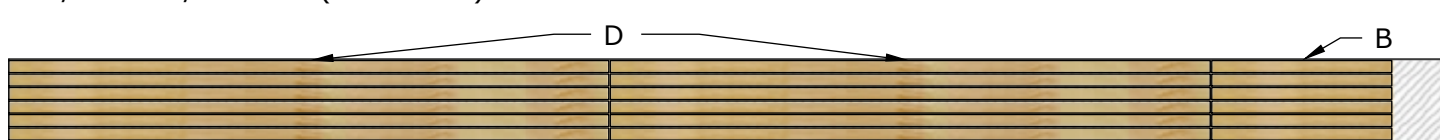

Parts cut from five boards, four 2x6 x 8' (1 1/2"x 5 1/2 x 96") and one 2x8 x 10' (1 1/2"x 7 1/4 x 120").

Start by removing the rounded sides of the 2x6. (1/8" from each side).



(<https://www.youtube.com/c/MatthewPeechWoodworkingAndDIY>)

2 Side Panel Top & Bottom Boards:

Cut parts to size and then cut the slat notch as shown in diagram.

Cutting slat notches into top and bottom side panel boards on the table saw.

Set fence to $\frac{3}{8}$ " and the blade height to $\frac{1}{2}$ ". Run side panel boards through the saw on edge. Then rotate the board and repeat the cut leaving the boards as shown. Set fence to $\frac{9}{16}$ " to remove the remaining material.

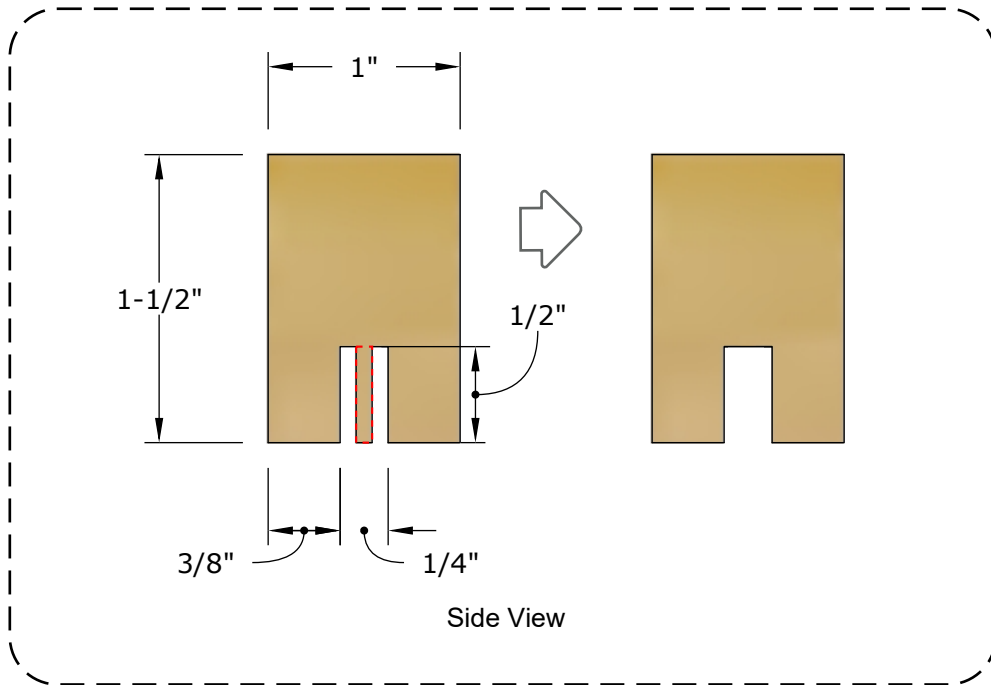
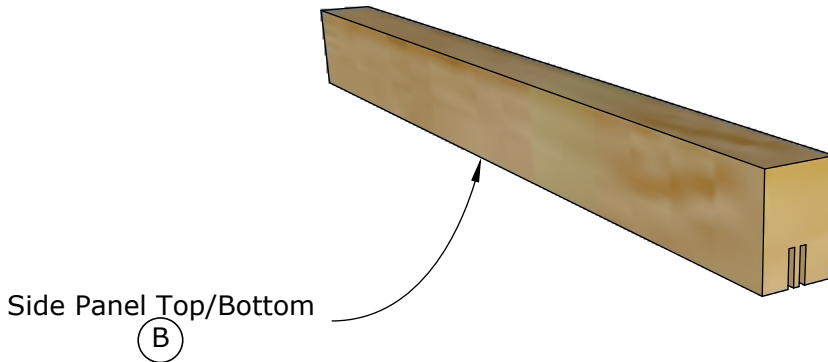

(<https://www.youtube.com/c/MatthewPeechWoodworkingAndDIY>)

3 Slats:

After cutting slats into 1/4" thick strips from the 1 1/2" material you will lay slats flat and then cut to 1" widths.

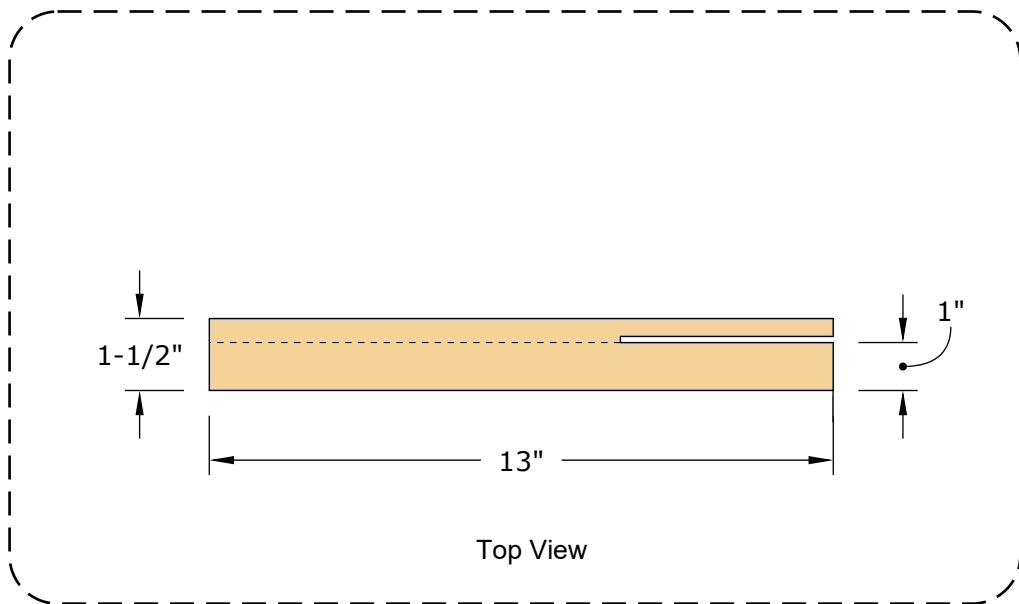
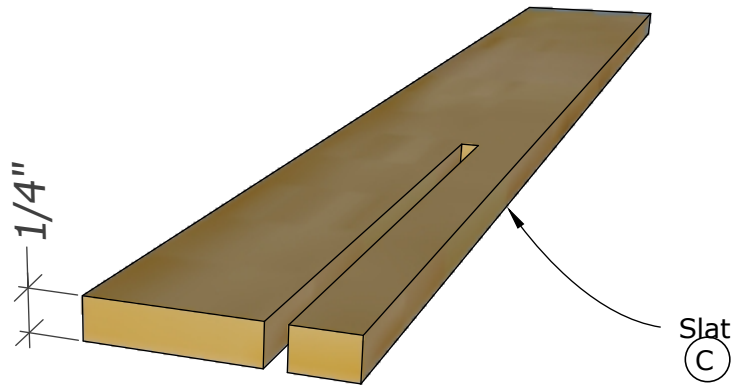

(<https://www.youtube.com/c/MatthewPeechWoodworkingAndDIY>)

4 Cutting Decorative Top Onto Legs:

Measure and mark a line 1" from the end of your leg on all sides.
Bevel miter saw to the left at 35°. Cut all 4 sides. Repeat for all legs.

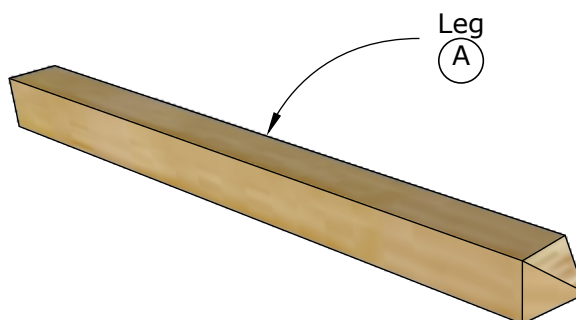
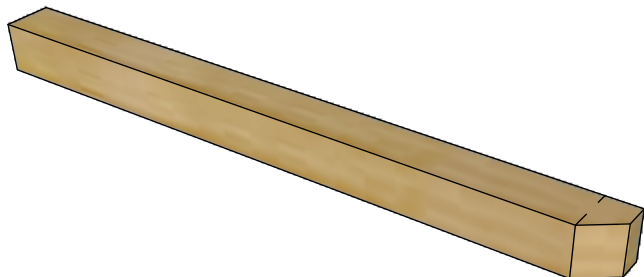

Note: Paint or stain the parts at this point if desired.

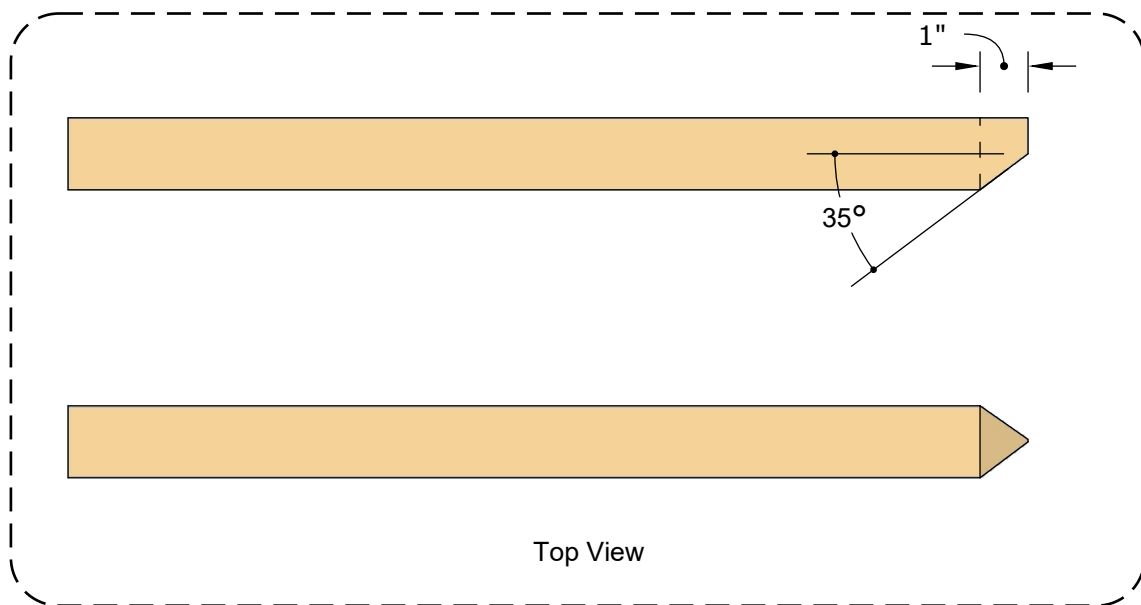

(<https://www.youtube.com/c/MatthewPeechWoodworkingAndDIY>)

5 Assemble Side Panels:

Place exterior wood glue into top and bottom board notches.

Place 12 slats into notches. Leave 1/4" spacing between each slat.

Place a 3/4" brad nail 1/4" from the inside edge of top and bottom boards where each slat is inserted. This will hold the slats into place while the glue dries.

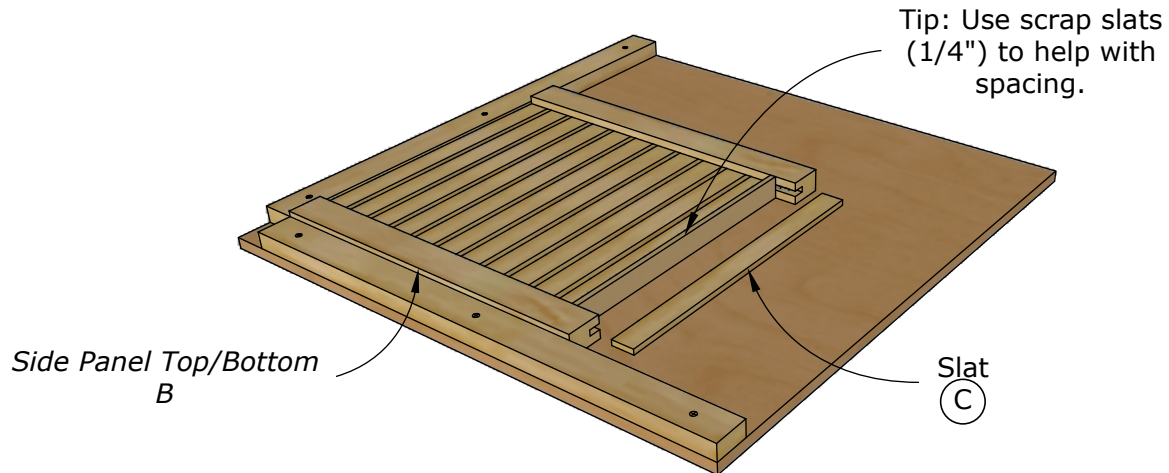

Tip: To make assembly easier assemble a jig. As seen in diagram.

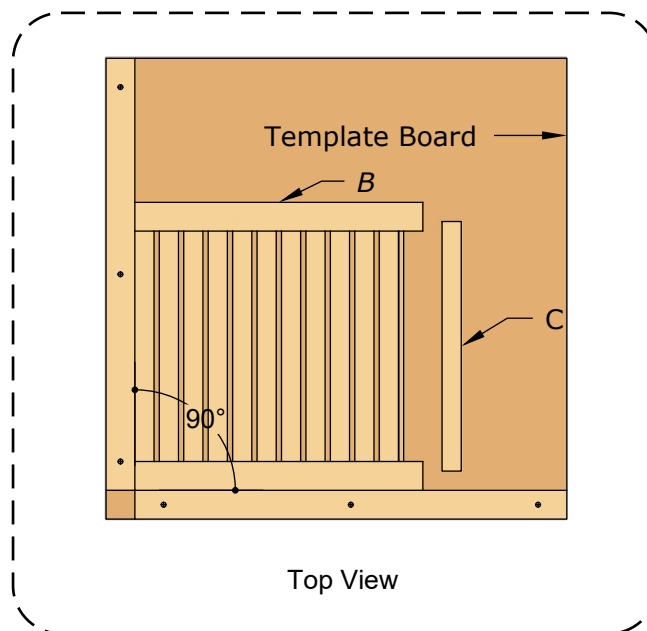

(<https://www.youtube.com/c/MatthewPeechWoodworkingAndDIY>)

6 Side Pocket Holes:

Place pocket holes into the ends of each panel top and bottom board.

Set your drill bit collar to 1" setting..

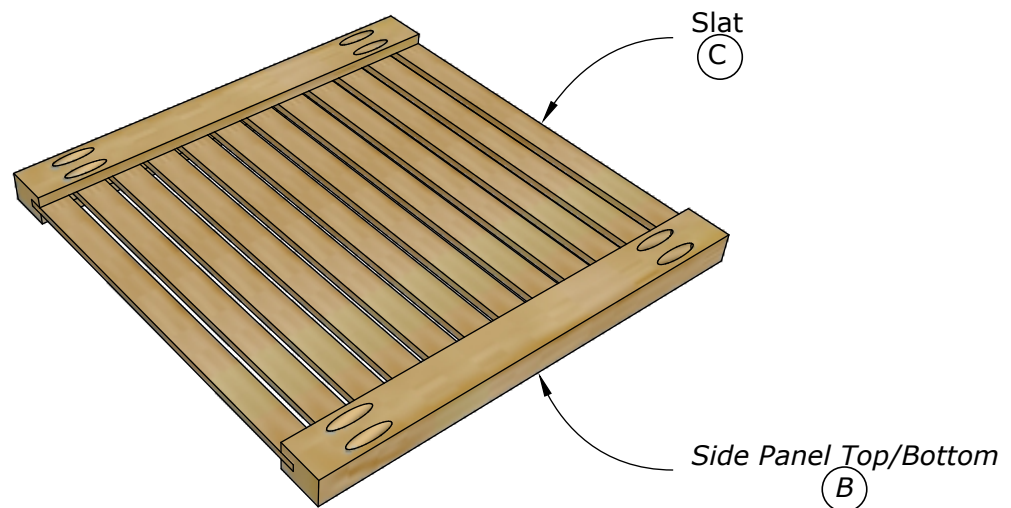

(<https://www.youtube.com/c/MatthewPeechWoodworkingAndDIY>)

7 Side Assembly:

Attach Side walls to legs using 1 1/4" pocket hole screws. Glue if desired.

The Panels should be centered on the leg 1/4" from each edge.

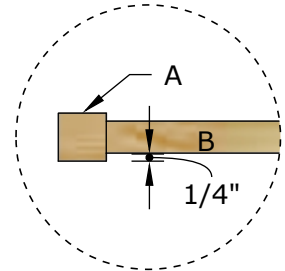
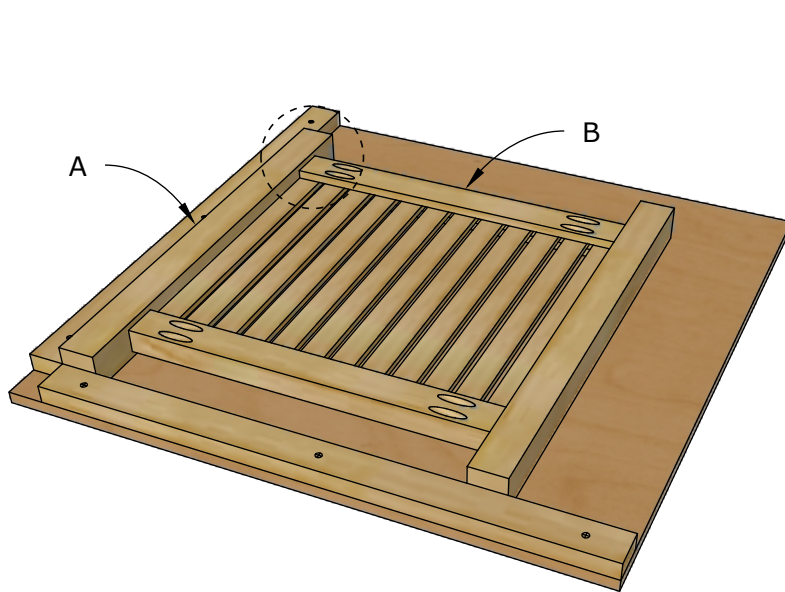

Tip: Use scrap slats under the panel to raise it 1/4".

Tip: Make a 2 1/4" spacer jig to use with your previous jig to ensure exact panel placement.

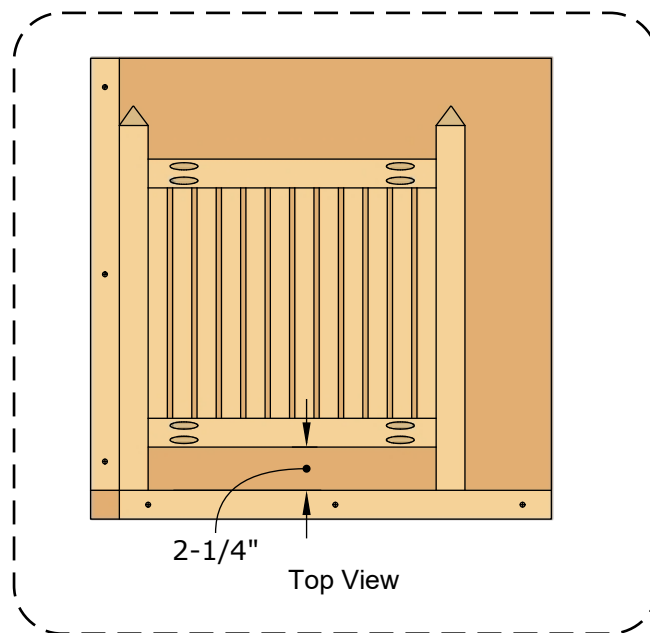

(<https://www.youtube.com/c/MatthewPeechWoodworkingAndDIY>)

8

Planter Assembly:

Repeat for all sides making sure to leave 1/4" spacing from the outer edge of each leg.

Align and attach. Repeat planter steps for as many as desired.

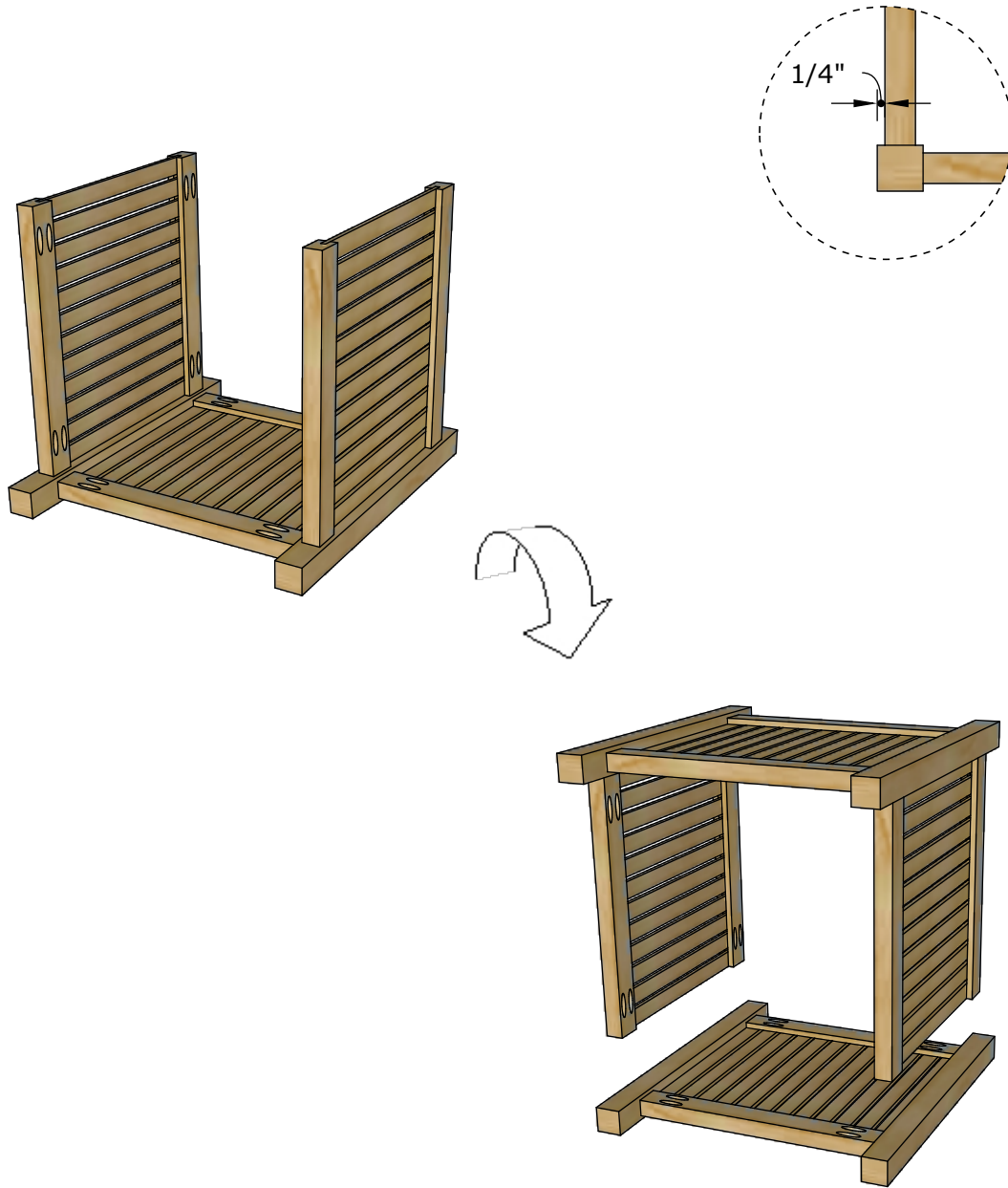

(<https://www.youtube.com/c/MatthewPeechWoodworkingAndDIY>)

9 Cut Parts For Bench:

Start by cutting all bench parts to 1" x 1 1/2" strips.

For parts E, place parts on edge and rip down to 1 1/4" wide.

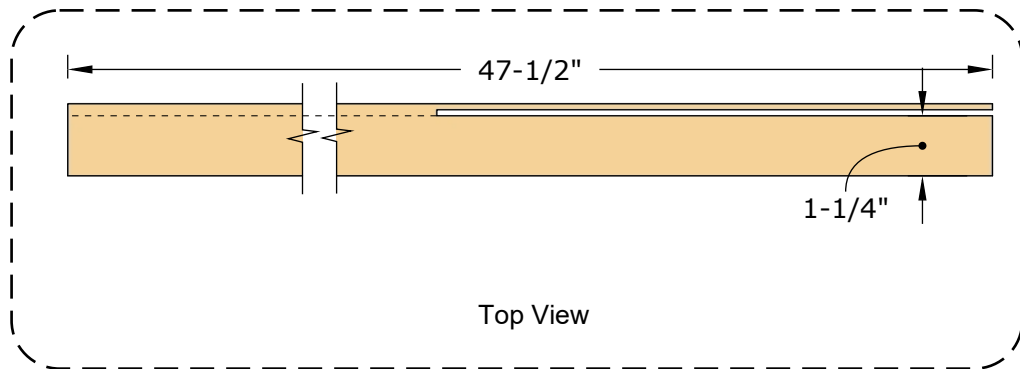
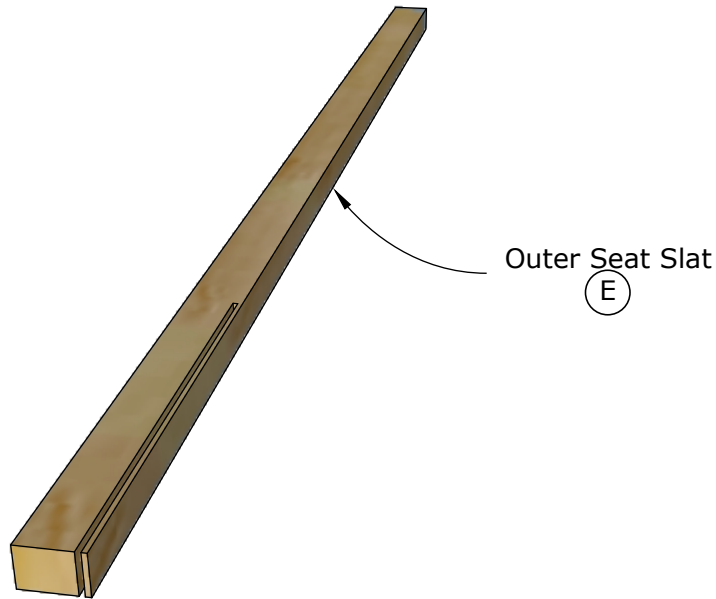

(<https://www.youtube.com/c/MatthewPeechWoodworkingAndDIY>)

10 Bench Pocket Holes:

Place pocket holes into both ends of all parts F and G.

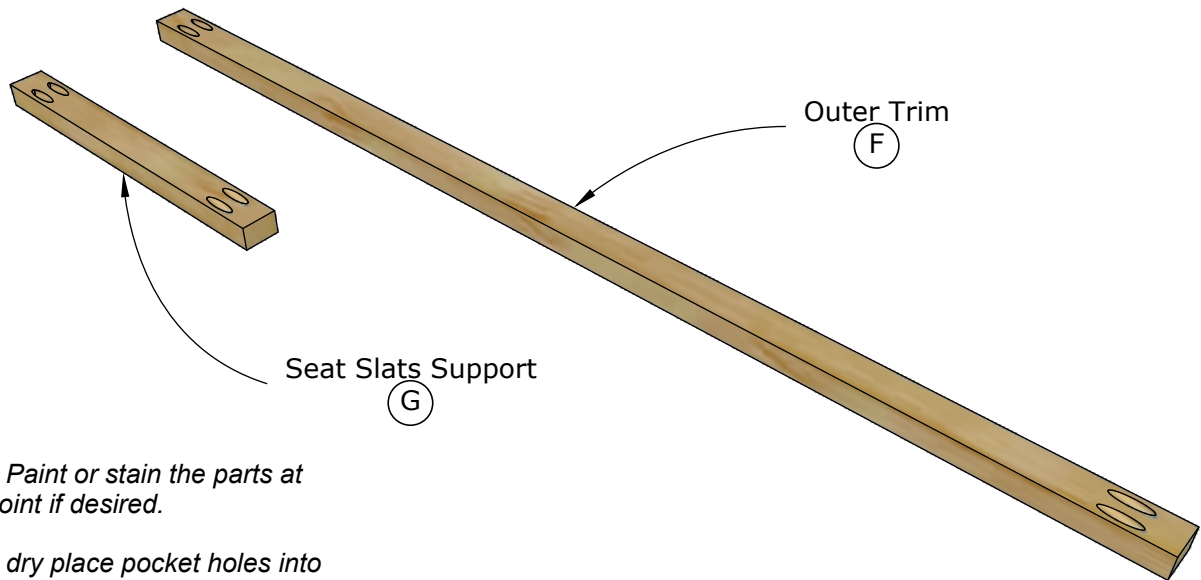

Note: Paint or stain the parts at this point if desired.

Once dry place pocket holes into the ends of both outer trim boards.



(<https://www.youtube.com/c/MatthewPeechWoodworkingAndDIY>)

11 Attach Outer Seat Slats To Outer Trim Boards :

With the outer trim board on edge and the pocket holes facing in, place outer seat slats on top laying flat. The outer edges of both boards should be flush leaving a 1/4" overhang facing in as shown in the diagram.

Attach using wood glue and 1 1/2" brad nails.

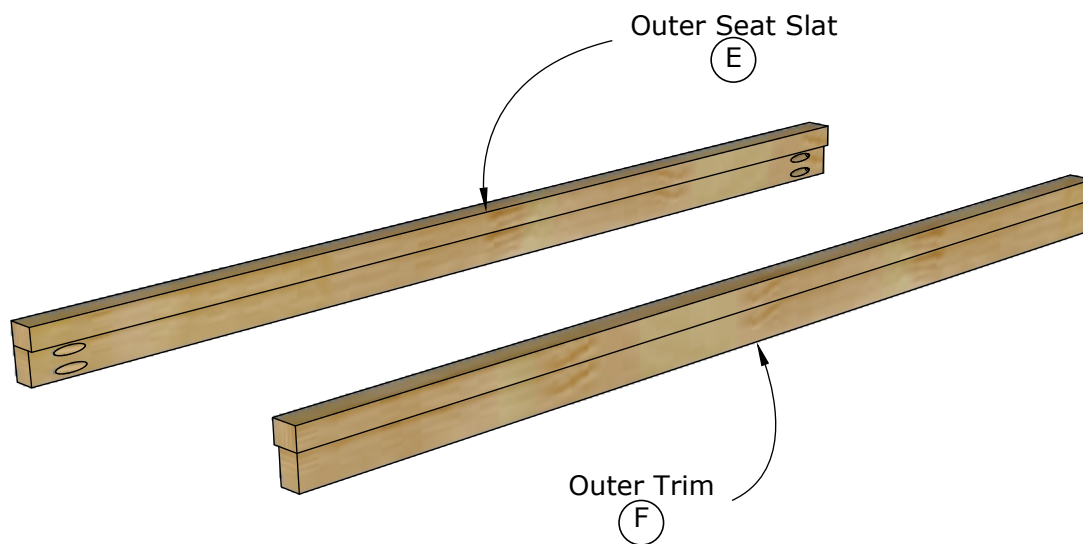

(<https://www.youtube.com/c/MatthewPeechWoodworkingAndDIY>)

12 Bench Assembly:

With all bench parts facing down, lay out all parts as shown in the diagram.

Place seat slat supports 12" from each end. Once everything is spaced correctly lock into place using 2 clamps.

Inner seat slats are 1 1/4" longer on each end.

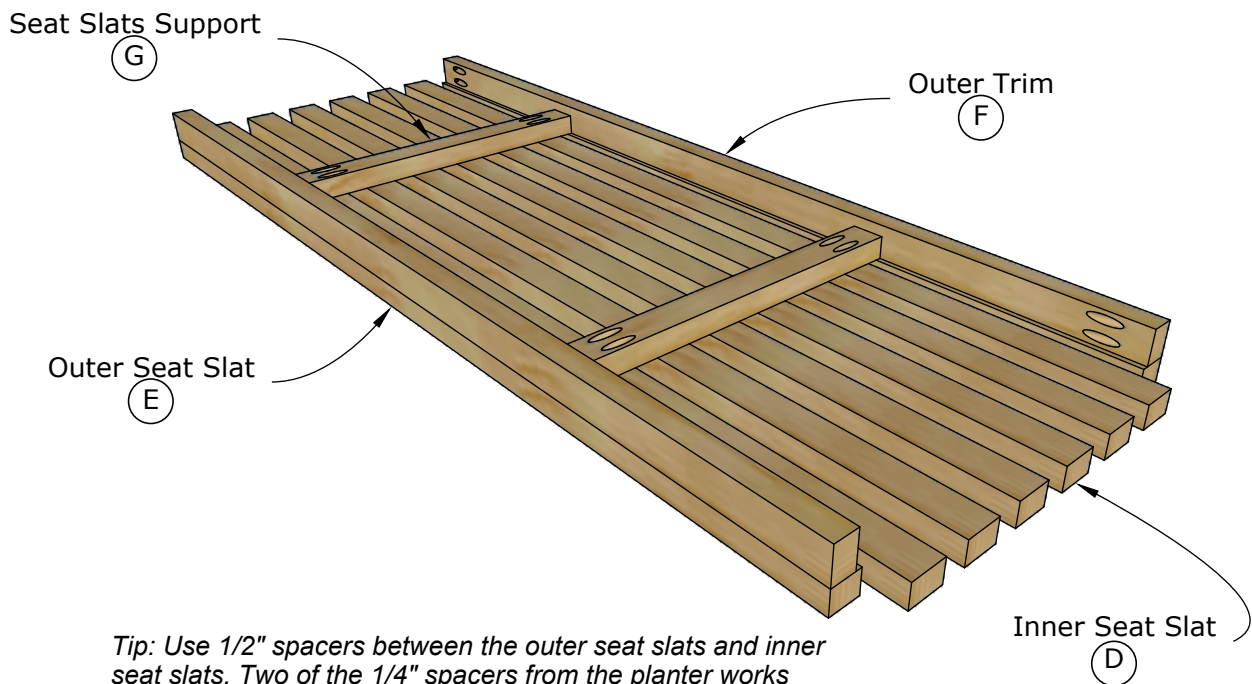

Tip: Use 1/2" spacers between the outer seat slats and inner seat slats. Two of the 1/4" spacers from the planter works perfect for this.

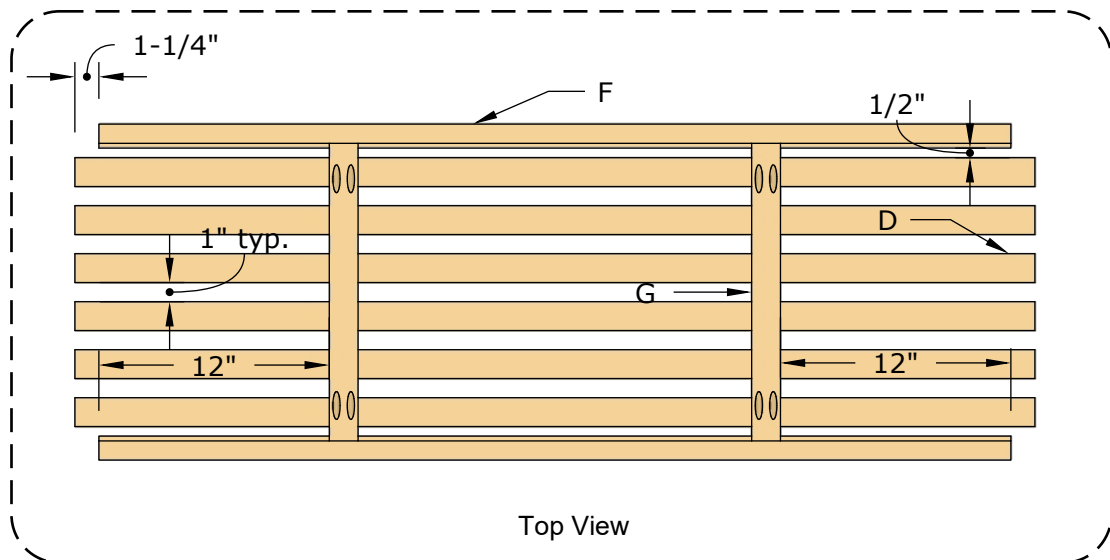

Tip: Use 1" scraps from seat boards as spacers between all inner seat slats.



(<https://www.youtube.com/c/MatthewPeechWoodworkingAndDIY>)

13 Apply Fasteners:

Attach seat slat supports to side trim using 1 1/4" pocket hole screws

Pre-drill and counter bore seat slat supports where they intersect each seat slat.

Attach using 1 1/4" pocket hole screws.

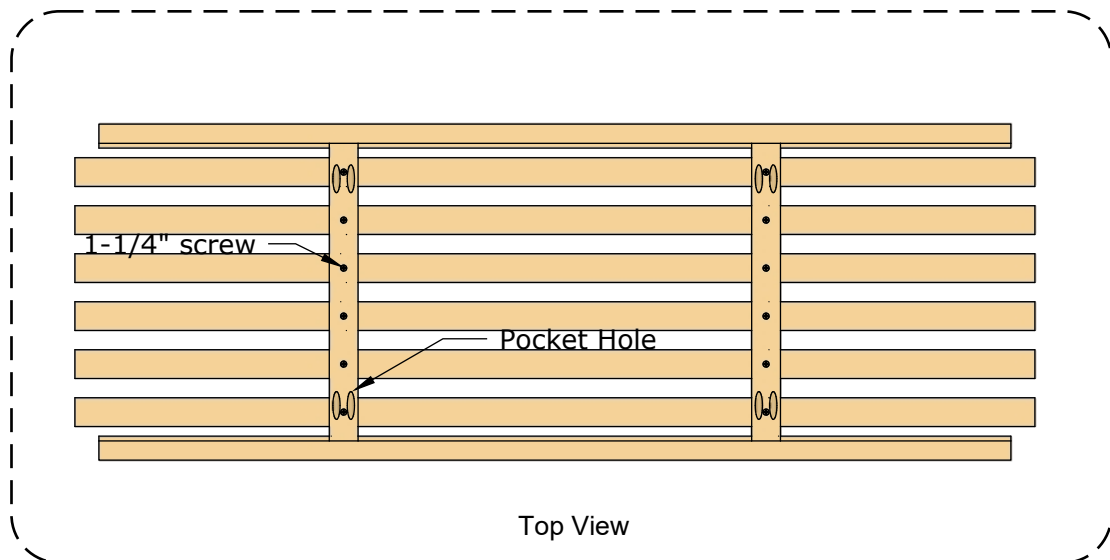
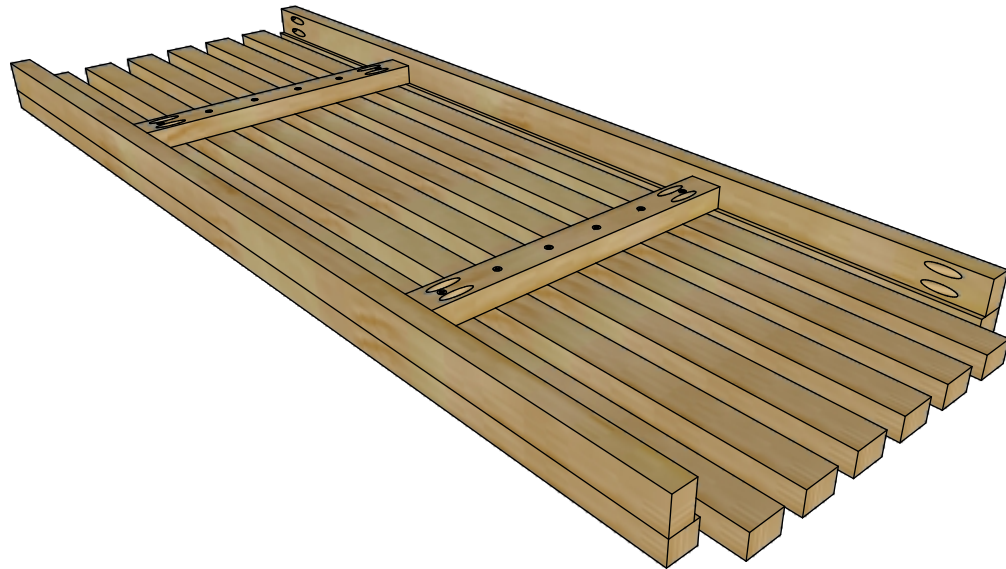

(<https://www.youtube.com/c/MatthewPeechWoodworkingAndDIY>)

14 Place Bench onto Planters:

Using the pre-drilled pocket holes in the side trim boards, attach bench to planter legs from underneath using 1 1/4" pocket hole screws.

Repeat steps for second bench if desired.

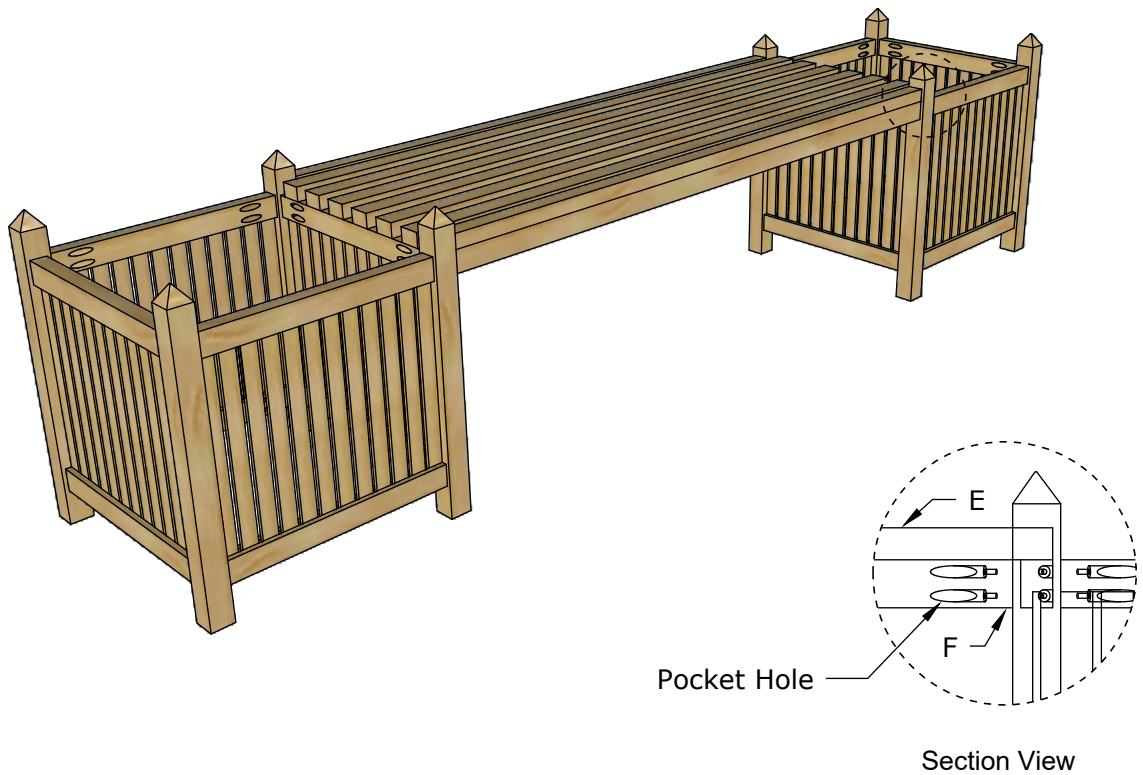

(<https://www.youtube.com/c/MatthewPeechWoodworkingAndDIY>)