



This PDF document and its contents cannot be sold or used without written permission from ZING WOODWORKS LLC
 Plans, wording and graphics Copyright owned by ZING WOODWORKS LLC



DRAWN: MN	DATE 7/14/2021	ZING WOODWORKS LLC	
CHECKED: N/A		SQUARE CEDAR PLANTER	
QA N/A			
UNLESS OTHERWISE SPECIFIED: DIMENSIONS ARE IN INCHES TOLERANCES: ± 0.0625 in		SIZE D	DWG NO TITLE PAGE
		SCALE 1 / 3	PAGE A1
			REV 0

COPYRIGHT

This work and any wording or graphics found in these woodworking plans are for personally use only.
This PDF document and its contents cannot be sold or used without written permission from Zing Woodwork LLC

Plans, wording and graphics Copyright owned by Zing Woodworks LLC

SAFETY WARNING

Woodworking machinery can cause injury from improper operation or from poor maintenance.
Individual machines must be evaluated for specific operating hazards.

Make sure you use hand, eye and hearing protection when using power equipment & always practice safety.

Zing Woodworks LLC is not responsible for an injuries or harm caused by improper power tool use
or any injuries related to building this project.

TOOLS NEEDED

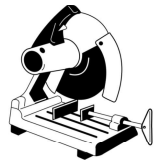

MITER SAW



BRAD NAILER

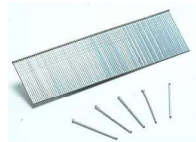

TABLE SAW

MATERIALS NEEDED



CEDAR FENCE
PICKET
(NEED QUANTITY 9
of 5.5in x 6ft PANEL)



16 Ga & 18 Ga
NAILS



WOOD GLUE
(EXTERIOR GRADE)

SPECIAL INSTRUCTIONS

- 1) This entire planter can be build using only wood glue, 16 Ga, and 18 Ga nails.
- 2) Make sure to use adequate amount of wood glue.
But not too much to prevent glue dripping down.
- 3) Use table saw to rip the 5.5" board to the size of 2.5"



DRAWN: MN	DATE 7/14/2021	ZING WOODWORKS LLC	
CHECKED: N/A		SQUARE CEDAR PLANTER	
QA N/A		SIZE D	DWG NO NOTES PAGE
UNLESS OTHERWISE SPECIFIED: DIMENSIONS ARE IN INCHES TOLERANCES: ± 0.0625 in		SCALE	PAGE B1
			REV 0

SQUARE CEDAR PLANTER - PARTS LIST

ITEM	QTY	PART NUMBER	MATERIAL
1	4	4.875x24 CORNER CUT	CEDAR
2	4	5.5x24 CORNER CUT-LARGE	CEDAR
3	4	5.5x22 MIDDLE PANEL	CEDAR
4	4	2.5 HORIZONTAL MOULDING	CEDAR
5	4	2.5 HORIZONTAL MOULDING - 1	CEDAR
6	8	2.5 VERTICAL MOULDING	CEDAR
7	2	2.5 DIAGONAL MOULDING	CEDAR
8	2	2.5 DIAGONAL MOULDING - 1	CEDAR
9	2	INNER SUPPORTING BAR	CEDAR
10	2	4.875x15.25 BOTTOM SUPPORT - SIDE	CEDAR
11	1	5.5x15.375 BOTTOM SUPPORT - MIDDLE	CEDAR
12	4	2.5 TOP MOULDING	CEDAR

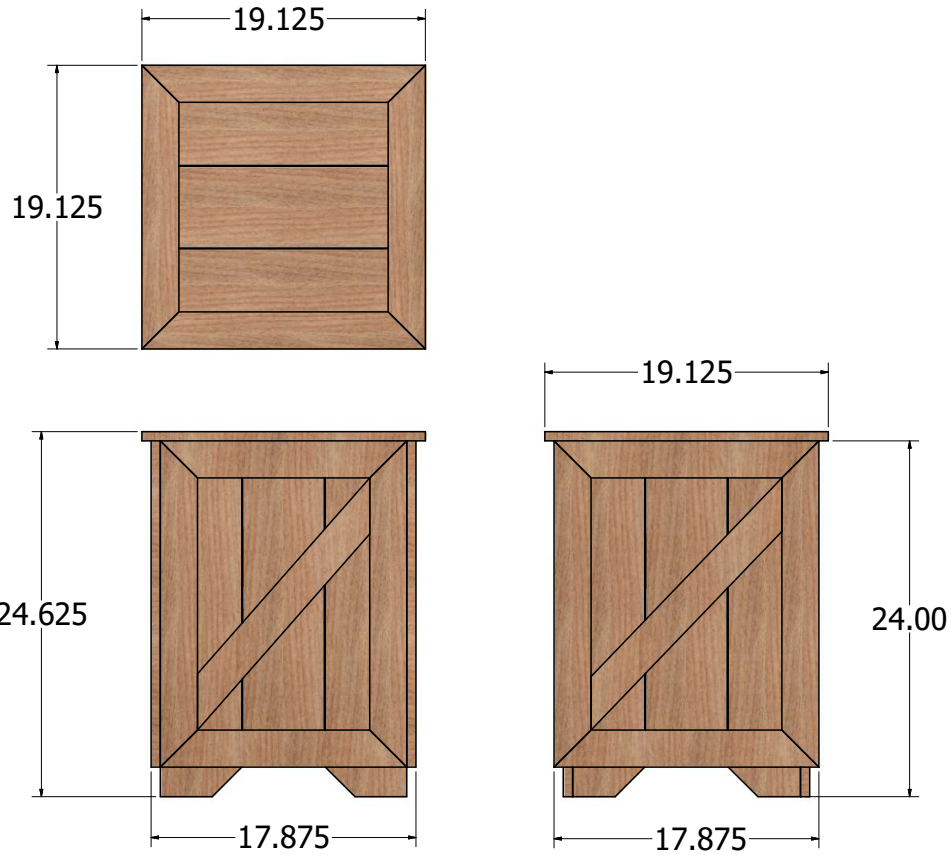
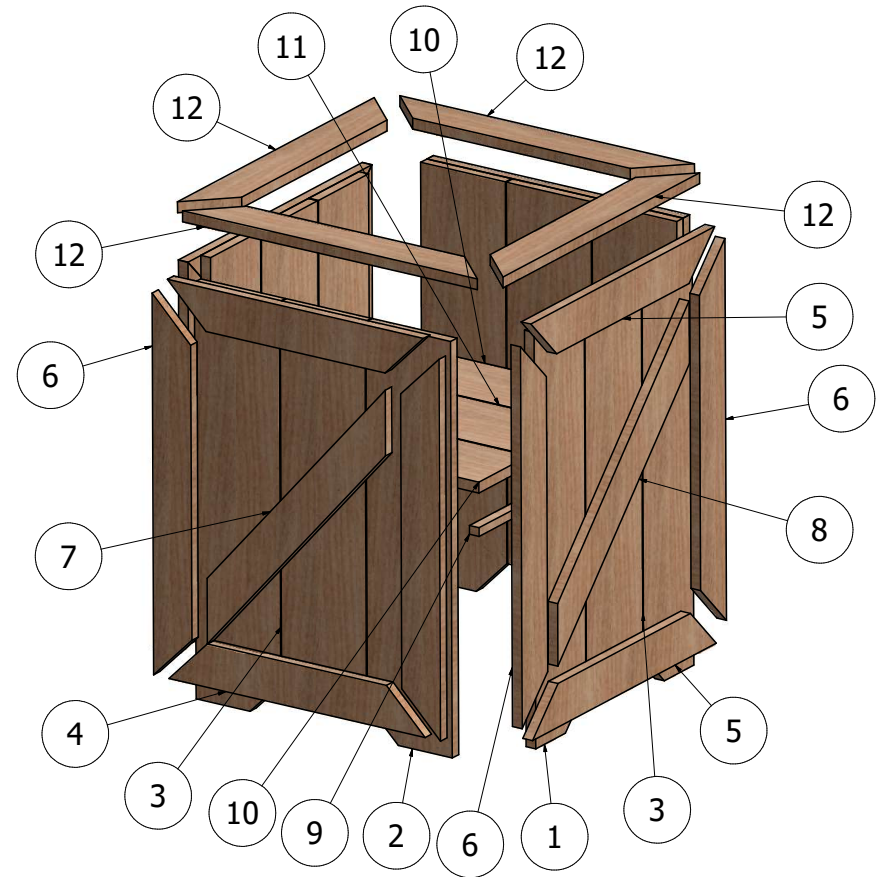

This PDF document and its contents cannot be sold or used without written permission from ZING WOODWORKS LLC
Plans, wording and graphics Copyright owned by ZING WOODWORKS LLC



DRAWN: MN	DATE 7/14/2021	ZING WOODWORKS LLC	
CHECKED: N/A		SQUARE CEDAR PLANTER	
QA N/A		SIZE D	DWG NO TOTAL ASSEMBLY
UNLESS OTHERWISE SPECIFIED: DIMENSIONS ARE IN INCHES TOLERANCES: ± 0.0625 in		SCALE 1/4	PAGE C1 REV 0

CUT LIST

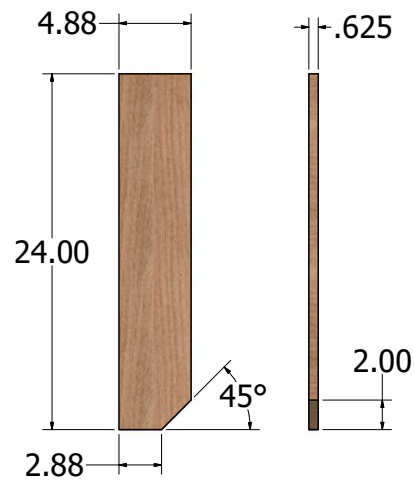

1 4.875x24 CORNER CUT
MATERIAL: CEDAR
QTY: 4

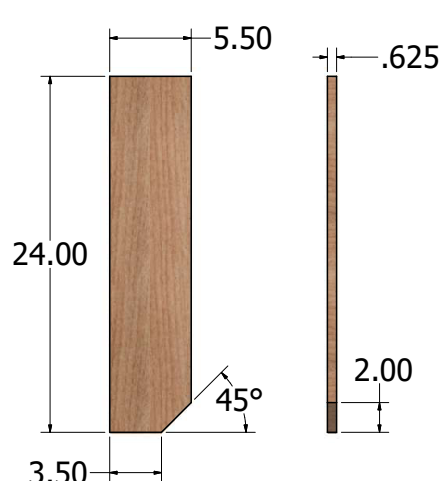

2 5.5x24 CORNER CUT-LARGE
MATERIAL: Cedar
QTY: 4

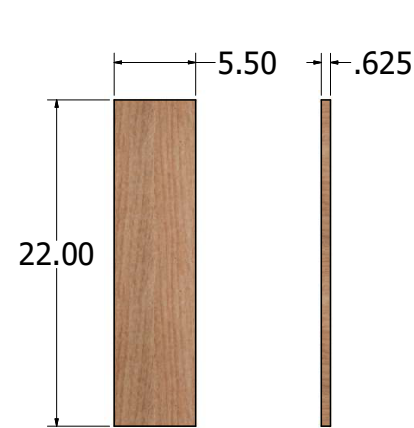

3 5.5x22 MIDDLE PANEL
MATERIAL: CEDAR
QTY: 4

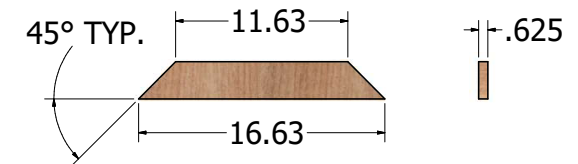

4 2.5 HORIZONTAL MOULDING
MATERIAL: CEDAR
QTY: 4

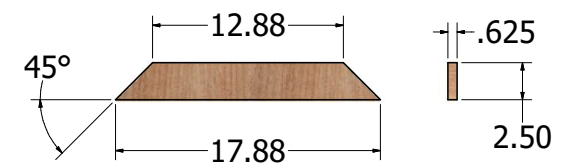

5 2.5 HORIZONTAL MOULDING - 1
MATERIAL: CEDAR
QTY: 4

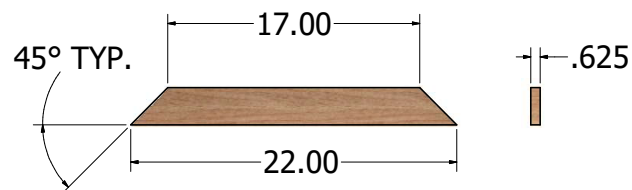

6 2.5 VERTICAL MOULDING
MATERIAL: CEDAR
QTY: 8

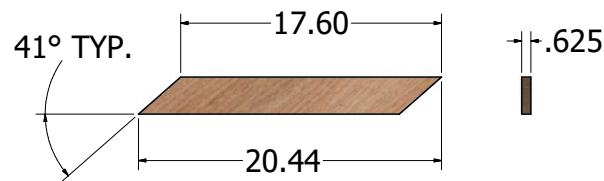

7 2.5 DIAGONAL MOULDING
MATERIAL: CEDAR
QTY: 2

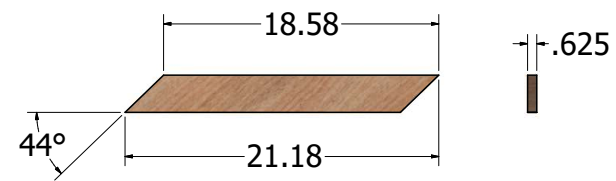

8 2.5 DIAGONAL MOULDING - 1
MATERIAL: CEDAR
QTY: 2

This PDF document and its contents cannot be sold or used without written permission from ZING WOODWORKS LLC
Plans, wording and graphics Copyright owned by ZING WOODWORKS LLC



DRAWN: MN	DATE 7/14/2021	ZING WOODWORKS LLC	
CHECKED: N/A		SQUARE CEDAR PLANTER	
QA N/A		SIZE D	DWG NO TOTAL ASSEMBLY
UNLESS OTHERWISE SPECIFIED: DIMENSIONS ARE IN INCHES TOLERANCES: ± 0.0625 in		SCALE 1 / 5	PAGE C2

A

CUT LIST CONT.

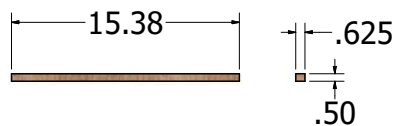

9 INNER SUPPORTING BAR
MATERIAL: CEDAR
QTY: 2

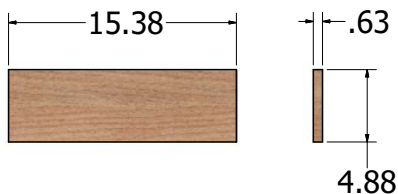

10 4.875x15.25 BOTTOM SUPPORT - SIDE
MATERIAL: CEDAR
QTY: 2

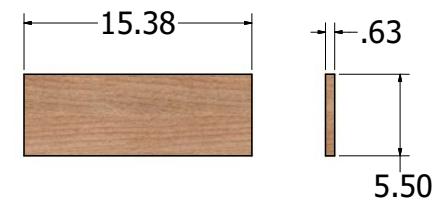

11 5.5x15.375 BOTTOM SUPPORT - MIDDLE
MATERIAL: Wood (Birch)
QTY: 1

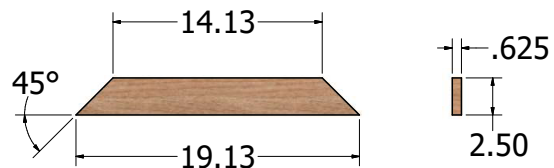

12 2.5 TOP MOULDING
MATERIAL: CEDAR
QTY: 4



DRAWN: MN	DATE 7/14/2021	ZING WOODWORKS LLC	
CHECKED: N/A		SQUARE CEDAR PLANTER	
QA N/A			
UNLESS OTHERWISE SPECIFIED: DIMENSIONS ARE IN INCHES TOLERANCES: ± 0.0625 in		SIZE D	DWG NO TOTAL ASSEMBLY
		SCALE 1:5	PAGE C3
			REV 0

STEP 1: FRONT PANEL ASSEMBLY

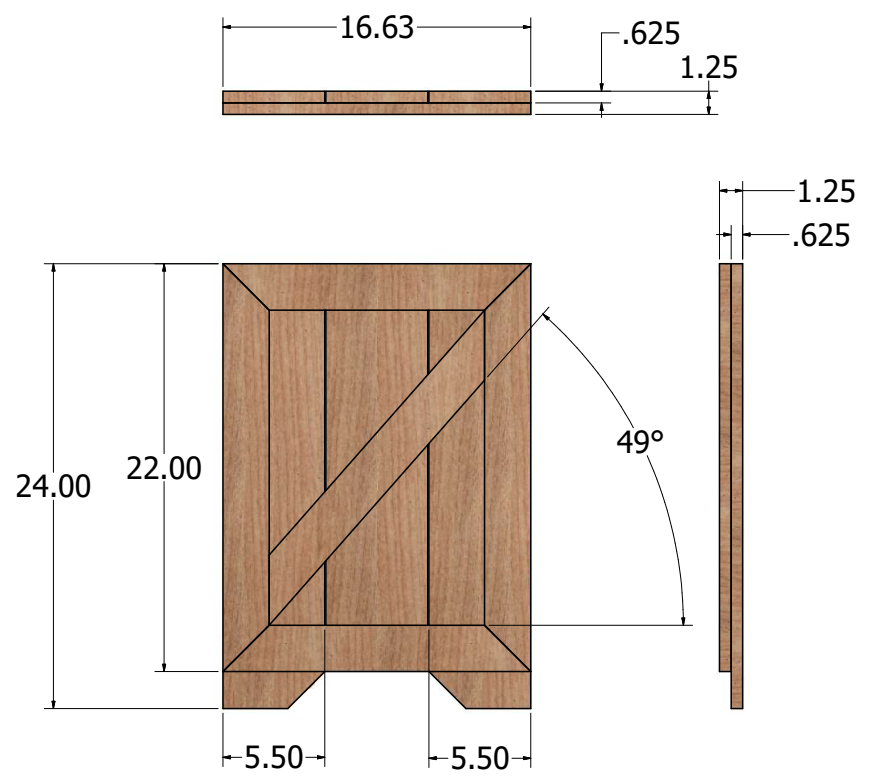

APPLY WOOD GLUE &
USE BRAD NAILER TO
SHOOT 1" 18Ga NAILS

QTY 2 NEEDED

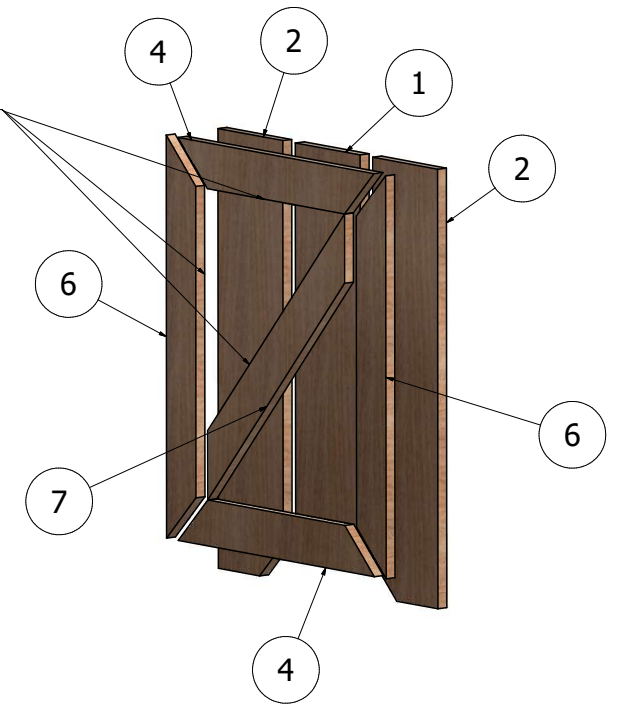
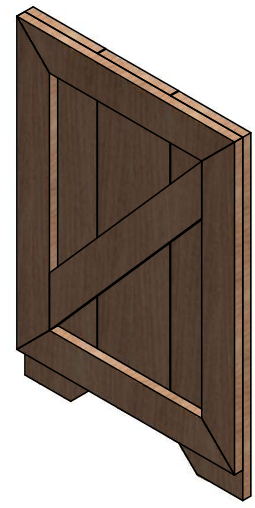

This PDF document and its contents cannot be sold or used without written permission from ZING WOODWORKS LLC
Plans, wording and graphics Copyright owned by ZING WOODWORKS LLC



DRAWN: MN	DATE 7/14/2021	ZING WOODWORKS LLC	
CHECKED: N/A	QA N/A	SQUARE CEDAR PLANTER	
UNLESS OTHERWISE SPECIFIED: DIMENSIONS ARE IN INCHES TOLERANCES: ± 0.0625 in		SIZE D	DWG NO BUILDING STEPS
		SCALE	PAGE D1
			REV 0

STEP 2: SIDE PANEL ASSEMBLY

APPLY WOOD GLUE &
USE BRAD NAILER TO
SHOOT 1" 18Ga NAILS

QTY 2 NEEDED

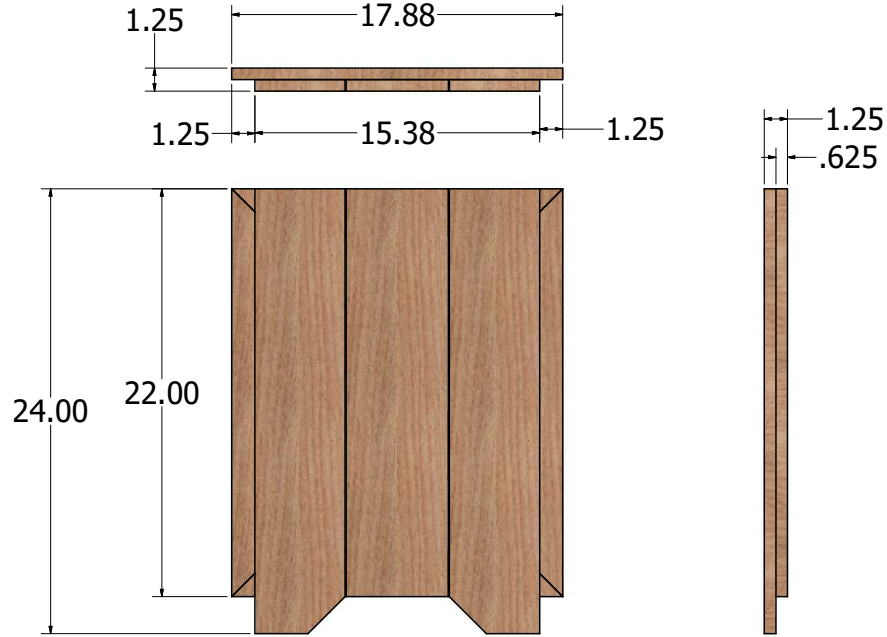
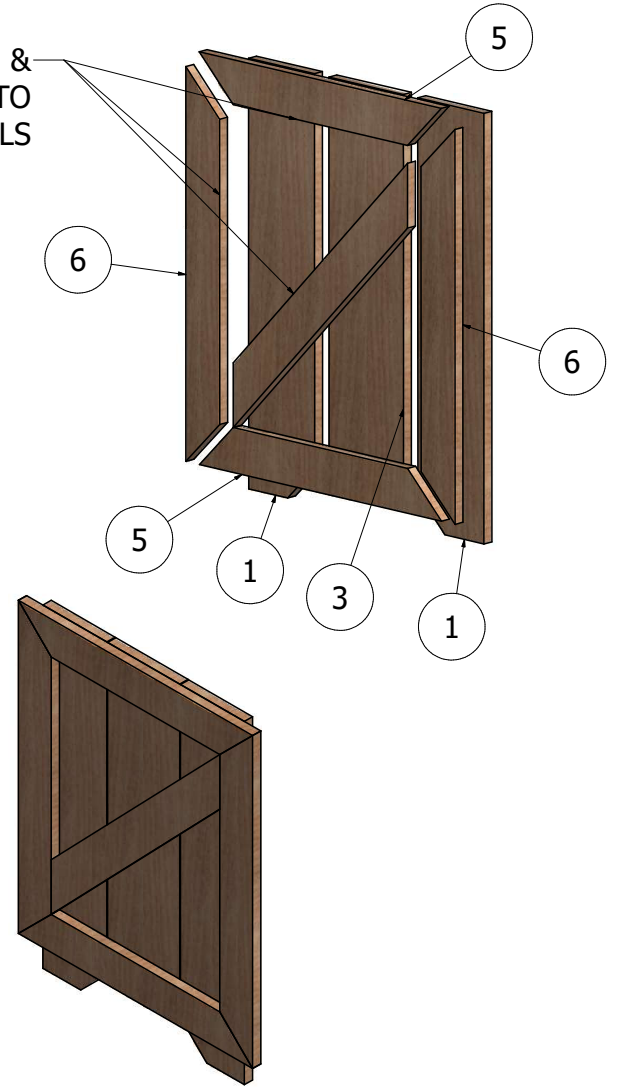

VIEW FROM INSIDE

This PDF document and its contents cannot be sold or used without written permission from ZING WOODWORKS LLC
Plans, wording and graphics Copyright owned by ZING WOODWORKS LLC



DRAWN: MN	DATE 7/14/2021	ZING WOODWORKS LLC	
CHECKED: N/A		SQUARE CEDAR PLANTER	
QA N/A		SIZE D	DWG NO BUILDING STEPS
UNLESS OTHERWISE SPECIFIED: DIMENSIONS ARE IN INCHES TOLERANCES: ± 0.0625 in		SCALE	PAGE D2
			REV 0

STEP 3: PUTTING PANELS TOGETHER

MAKE SURE THE FRONT PANEL ASSEMBLY LOCKED IN WITH SIDE PANEL ASSEMBLY

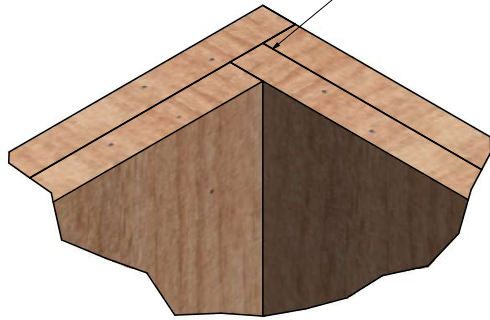

DETAIL A
SCALE 1 / 1

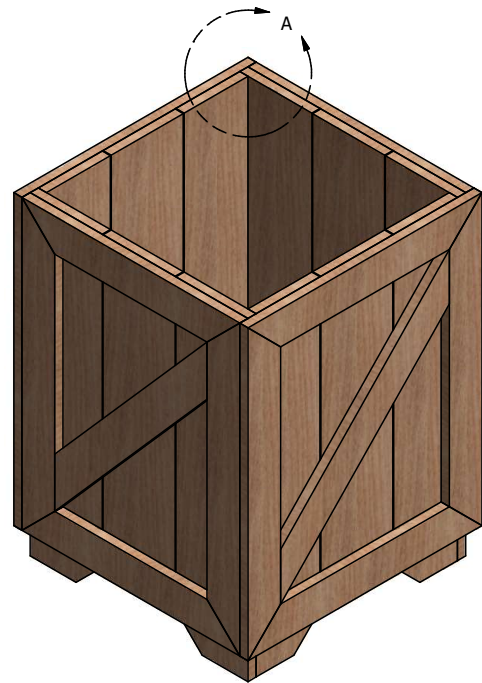

APPLY WOOD GLUE AND USE 16 Ga NAILS TO ATTACH THE FRONT AND SIDE PANELS

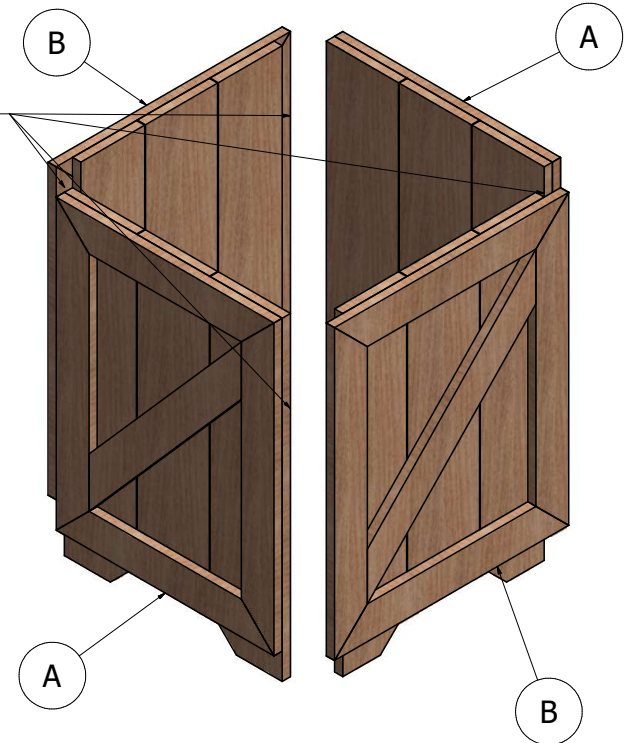

This PDF document and its contents cannot be sold or used without written permission from ZING WOODWORKS LLC
Plans, wording and graphics Copyright owned by ZING WOODWORKS LLC



DRAWN: MN	DATE 7/14/2021	ZING WOODWORKS LLC	
CHECKED: N/A		SQUARE CEDAR PLANTER	
QA N/A		SIZE D	DWG NO BUILDING STEPS
UNLESS OTHERWISE SPECIFIED: DIMENSIONS ARE IN INCHES TOLERANCES: ± 0.0625 in		SCALE	PAGE D3
			REV 0

STEP 4: ADDING BOTTOM SUPPORTING BARS

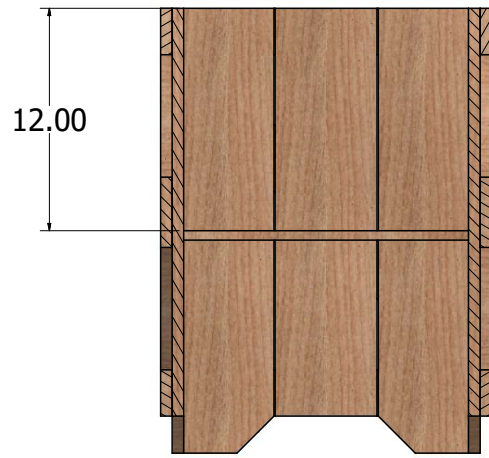

SECTION B-B

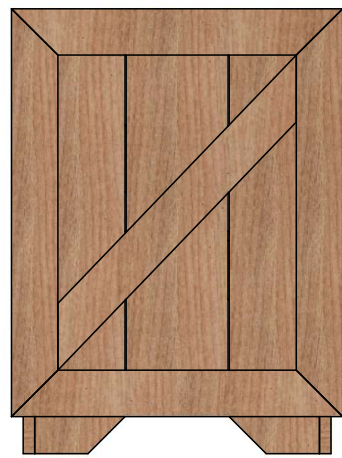
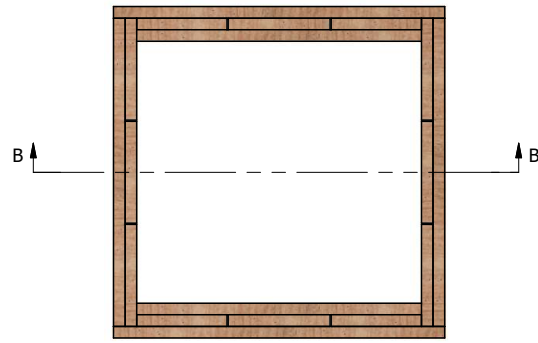

APPLY WOOD GLUE
AND USE 18 Ga NAILS
TO ATTACH



This PDF document and its contents cannot be sold or used without written permission from ZING WOODWORKS LLC
Plans, wording and graphics Copyright owned by ZING WOODWORKS LLC



DRAWN: MN	DATE 7/14/2021	ZING WOODWORKS LLC	
CHECKED: N/A		SQUARE CEDAR PLANTER	
QA N/A		SIZE D	DWG NO BUILDING STEPS
UNLESS OTHERWISE SPECIFIED: DIMENSIONS ARE IN INCHES TOLERANCES: ± 0.0625 in		SCALE	PAGE D4
			REV 0

STEP 5: ADDING BOTTOM PANELS

APPLY WOOD GLUE
AND USE 18 Ga
TO ATTACH

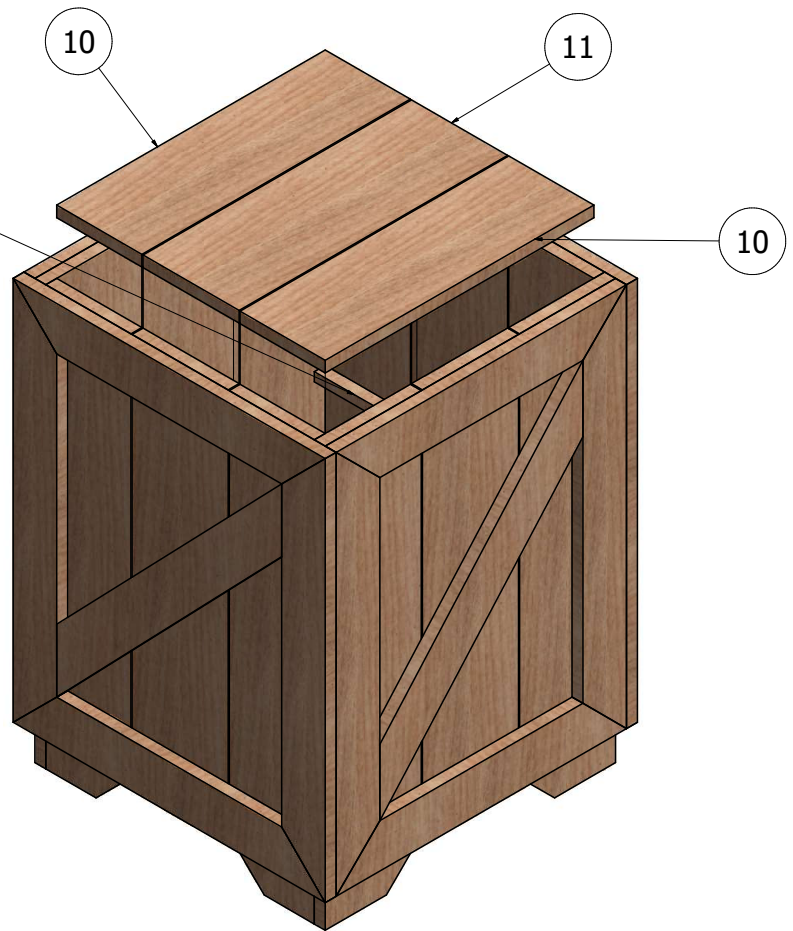

This PDF document and its contents cannot be sold or used without written permission from ZING WOODWORKS LLC
Plans, wording and graphics Copyright owned by ZING WOODWORKS LLC



DRAWN: MN	DATE 7/14/2021	ZING WOODWORKS LLC	
CHECKED: N/A		SQUARE CEDAR PLANTER	
QA N/A		SIZE D	DWG NO BUILDING STEPS
UNLESS OTHERWISE SPECIFIED: DIMENSIONS ARE IN INCHES TOLERANCES: ± 0.0625 in		PAGE D5	REV 0

**STEP 6: ADDING TOP MOULDING.
FINISHED PLANTER**

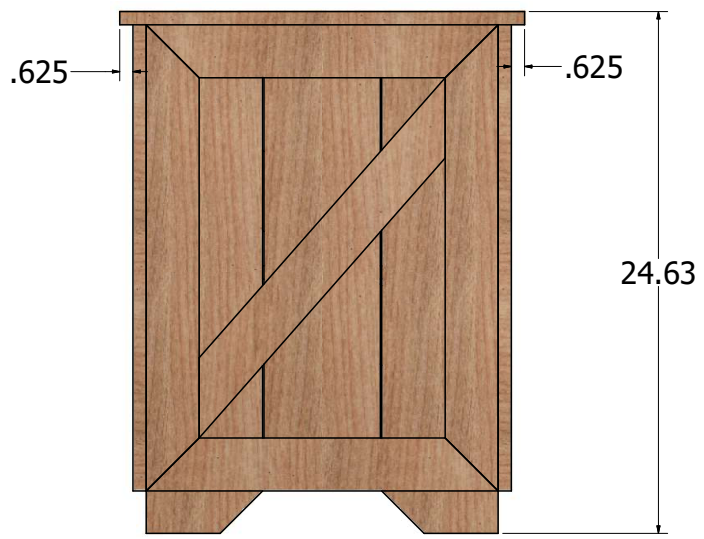
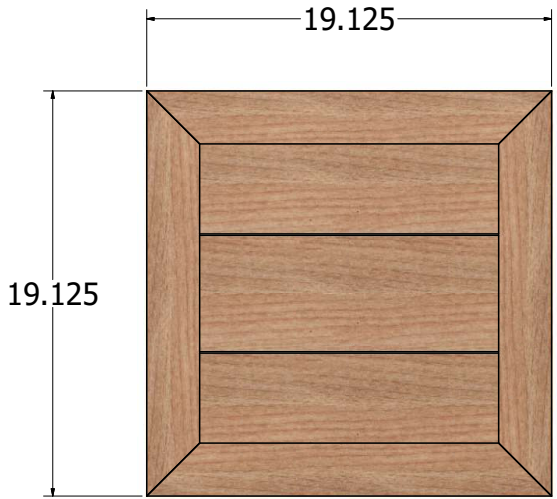

APPLY WOOD GLUE
AND USE 18 Ga
TO ATTACH

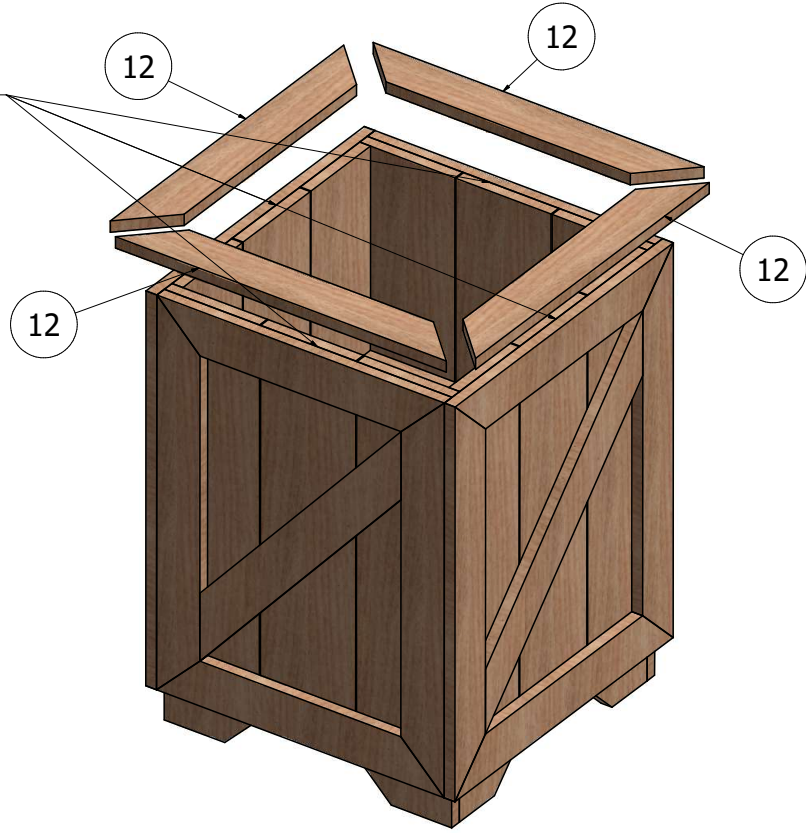

This PDF document and its contents cannot be sold or used without written permission from ZING WOODWORKS LLC
Plans, wording and graphics Copyright owned by ZING WOODWORKS LLC



DRAWN: MN	DATE 7/14/2021	ZING WOODWORKS LLC	
CHECKED: N/A		SQUARE CEDAR PLANTER	
QA N/A		SIZE D	DWG NO BUILDING STEPS
UNLESS OTHERWISE SPECIFIED: DIMENSIONS ARE IN INCHES TOLERANCES: ± 0.0625 in		SCALE	PAGE D6
			REV 0